



# ***THE FUTURES BAZAAR***

A PUBLIC IMAGINATION TOOLKIT



# THE FUTURES BAZAAR A PUBLIC IMAGINATION TOOLKIT

Created and written by Filippo Cuttica and Stuart Candy  
Illustrations by Marie Rasmussen  
Visual design by Ed Goldman and Marie Rasmussen

v1.0 – September 2022

Published by BBC UX&D and Situation Lab

[bbc.co.uk/gel/features/futures-bazaar-toolkit](https://bbc.co.uk/gel/features/futures-bazaar-toolkit)

## Licence terms

These assets are available for download on the following licence terms:

### You can:

Download the assets and use them free of charge;  
Use the assets without attribution (but we'd appreciate it if you could let us know); and  
Modify or alter the assets and edit them as you like.

### You can't:

Use the assets in a way that would bring the BBC into disrepute;  
Make available the assets so that they can be downloaded by others;  
Sell the assets to other people or package the assets with others that are for sale;  
Take payment from others to access the assets (including putting them behind a paywall);  
Use the assets as part of a service that you are charging money for; or  
Imply association with or endorsement from the BBC by using the assets.

**Disclaimer:** The assets are offered as is and the BBC is not responsible for anything that happens if you use them.

**Keywords:** critical making, design fiction, discursive design, experiential futures, facilitation, foresight, participatory design, play, product hacking, speculative design, team activities, toolkits, worldbuilding



# Thinking concretely about times and worlds to come is harder and rarer than it should be.

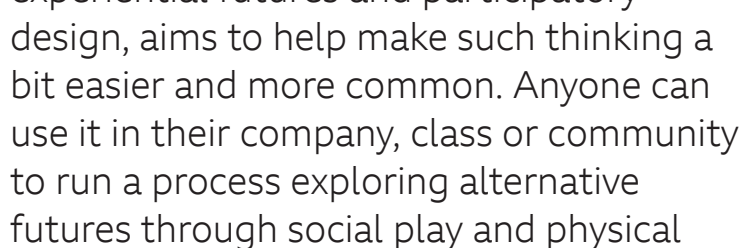

This toolkit, created in the traditions of experiential futures and participatory design, aims to help make such thinking a bit easier and more common. Anyone can use it in their company, class or community to run a process exploring alternative futures through social play and physical artefacts. We hope you have fun with it, and share what you do via **#FuturesBazaar**.



**Filippo Cuttica & Stuart Candy**

# THIS TOOLKIT

---

This toolkit is made up of three elements: **Manual**, **Slides**, and **Printouts**. All three elements are available for download as PDF files in a ZIP folder at [bbc.co.uk/gel/features/futures-bazaar-toolkit](http://bbc.co.uk/gel/features/futures-bazaar-toolkit)

## MANUAL

To help you plan your own event.



## SLIDES

To help you run it.

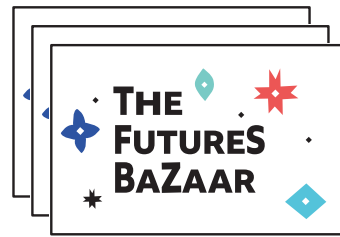

## PRINTOUTS

To distribute to participants on the day.

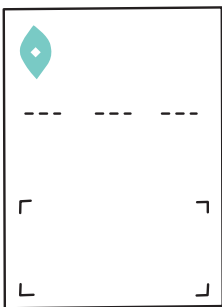

Warm up Sheet

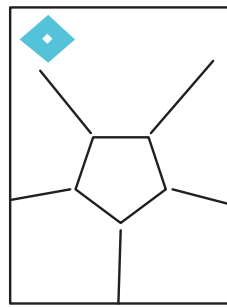

Explore Sheet

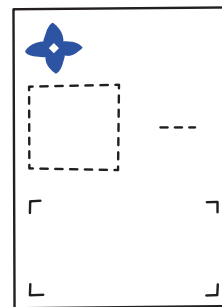

Ideate Sheet

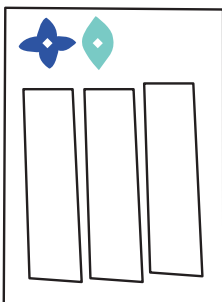

Prompt Sheet

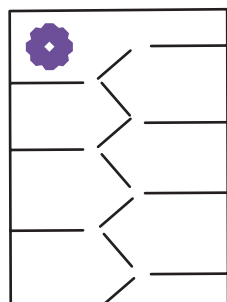

Artefact Tags

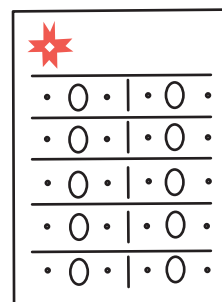

Bazaar Currency

# MANUAL CONTENTS

---

<b>Introduction</b> .....	6
<b>In Advance</b>	
Planning .....	7
Materials .....	8
Setting .....	9
Structure .....	10
Preview Of Final Outcome .....	11
<b>On The Day</b>	
Facilitating The Event .....	12
Step 0. Welcome .....	13
Step 1. Warm Up .....	14
Step 2. Explore .....	15
Step 3. Gather .....	16
Step 4. Ideate .....	17
Step 5. Create .....	18
Step 6. Set Up .....	19
Step 7. Run .....	20
Step 8. Take Down .....	22
<b>Afterwards</b>	
Sharing Outcomes .....	23
<b>Background</b> .....	24
<b>Authors</b> .....	25
<b>Acknowledgements</b> .....	26
<b>Facilitator's Cheat Sheet</b> .....	27



# INTRODUCTION

---

## WHAT?

The one thing we know for sure about the future is this: *it has not happened yet*. A Futures Bazaar is a wild and wonderful place where all possibilities co-exist at once – and can be physically encountered in real life. It is a kind of multi-dimensional exchange in which tangible objects are put on offer from countless potential worlds to come.

## HOW?

A Futures Bazaar gives any team, class or other group a structure for materialising and immersing in a crazy array of possible futures, using readily available materials. This Manual provides all the info you need to plan and create your own Futures Bazaar.

## WHY?

Just as we travel in order to have new experiences and see how others live, creating a Futures Bazaar is a way to journey into participants' imaginations. It offers a chance to expand horizons, explore new ideas, and develop capacities for foresight, creativity, and storytelling, all in just a few hours. We believe in the power of play to hone collective imagination – and a key to shaping better worlds is the ability to imagine them, together.

## WHO?

The Futures Bazaar is for everyone: no prior knowledge is needed. We have designed this Toolkit for players of all ages in all fields, and welcome its use in public and private organisations, government bodies, schools, NGOs and charities alike. We suggest at least 12 participants, but the more the merrier. A main organiser is needed – that might be you? – and then you and your colleagues, coworkers, students, or guests will bring it all to life.

## WHEN?

The Futures Bazaar can be done either as a stand-alone event such as a company away day, or within a larger workshop, course, or event series. It could be part of a journey towards building foresight capability, engaging alternative futures in more open and creative ways, or you could simply use it for fun, teambuilding purposes.

## WHENCE?

The first Futures Bazaar was staged at the BBC, as a way to playfully lower the bar to entry to thinking broadly about change, spanning many alternative futures. It worked so well that we soon tried it again in a completely different setting. In the spirit of “paying it forward”, we are now sharing the approach with a wider audience.

## WHITHER?

Having made this Toolkit, we hope others will experiment with The Futures Bazaar, and get as much out of it as participants have to date, enabling teambuilding through worldbuilding. We hope it will help make “the future” a bit less scary for some folks, perhaps sparking interest in learning more about experiential futures and participatory design. And we hope it will help pave the way to more playful, far-reaching conversations about the many challenges and opportunities that lie ahead – for our organisations, communities, and society at large – and how to navigate them.

# PLANNING

---

## TIME SET SOME ASIDE



The activity should be time-boxed. We recommend allowing 3–4 hours, although smaller groups may be able to move more quickly.

## SPACE FIND THE RIGHT ONE

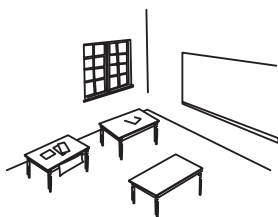

Part of the beauty of a bazaar is that it can scale up or down as needed. The size of the space required will depend on the number of participants. It should include some tables or desks to use as bazaar stalls; one per team. The space will also ideally include an A/V system; a computer with screen or projector to show the **Slides**, and a way to play music, or amplify announcements for larger groups.

## PEOPLE INVITE THEM



People are the most important part of all this! You'll want to get invitees excited, and provide a concise explanation of the event's aims. Feel free to repurpose text from the Introduction points above for your communications. If you are running a large event with dozens or hundreds of people, then arranging some help with facilitation and logistics may be wise. We suggest a team size of 3–4 people, with a minimum of 2 for smaller groups, and a maximum of 5–6.

## MATERIALS GET THEM READY

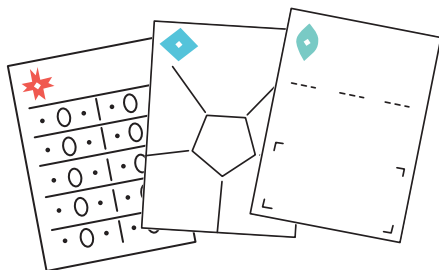

This Toolkit includes the **Manual** you are reading, some **Printouts** to distribute at the event, and a deck of **Slides** to use on the day. You will also need to source some basic materials yourself, including pens and paper, string, sticky tape, glue, scissors and boxcutters. Lastly, there is some junk material or “Future Fodder” that participants should be asked to bring with them. For a full breakdown of everything needed see the next section.

# MATERIALS

---

## SLIDES

A slide deck, to help the facilitator run the event, is provided as part of this Open Source Toolkit. It offers an introduction and scene-setting, followed by instructions for each exercise. Displaying the slides on a screen or projector will help guide participants through the workshop from beginning to end.

## PRINTOUTS

These are provided with the Toolkit. An approximate number of each element to print is recommended here, although your mileage may vary.

- Warm Up Sheets (2–3 sheets per person)
- Explore Sheets\* (1 sheet per team)
- Artefact Tags (1 tag per finished artefact)
- Ideate Sheet (10–12 sheets per team)
- Prompts Sheet\* (1 sheet per team)
- Bazaar Currency (half a sheet per person)

\* Optional: The Explore and Prompt Sheets, which are shared one per team, might be easier to use if printed in a larger format if possible (A3 or Tabloid vs. A4 or Letter).

## FUTURE FODDER

This material will be used as a starting point to generate Futures Bazaar artefacts. We suggest crowdsourcing this by asking participants to bring in three or four Future Fodder items each. Objects that they were otherwise planning to recycle or discard are ideal: examples might include a broken bicycle helmet, empty packaging, or a disused remote control from an old TV. Unique and unusual form factors can be particularly generative, which is something you could add when sending out the event invitation. You might also provide additional guidance on what to bring or not bring in the interests of safety (e.g. if your participant group includes children), or if you want to emphasise a certain aesthetic for the bazaar (e.g. electronic artefacts preferred – or no electronics allowed).

## ADDITIONAL MATERIALS

- Pens and markers
- Paper
- Sticky tape
- Scissors and Stanley knives
- Extra construction and decoration materials, e.g. glue guns, stickers, construction clay, coloured markers
- Supplementary Future Fodder (optional)

Participants may also be invited to bring construction materials from home that would otherwise go to waste (e.g. coloured paper, fabric, cardboard) for use in their banners and other stall decorations.



# SETTING

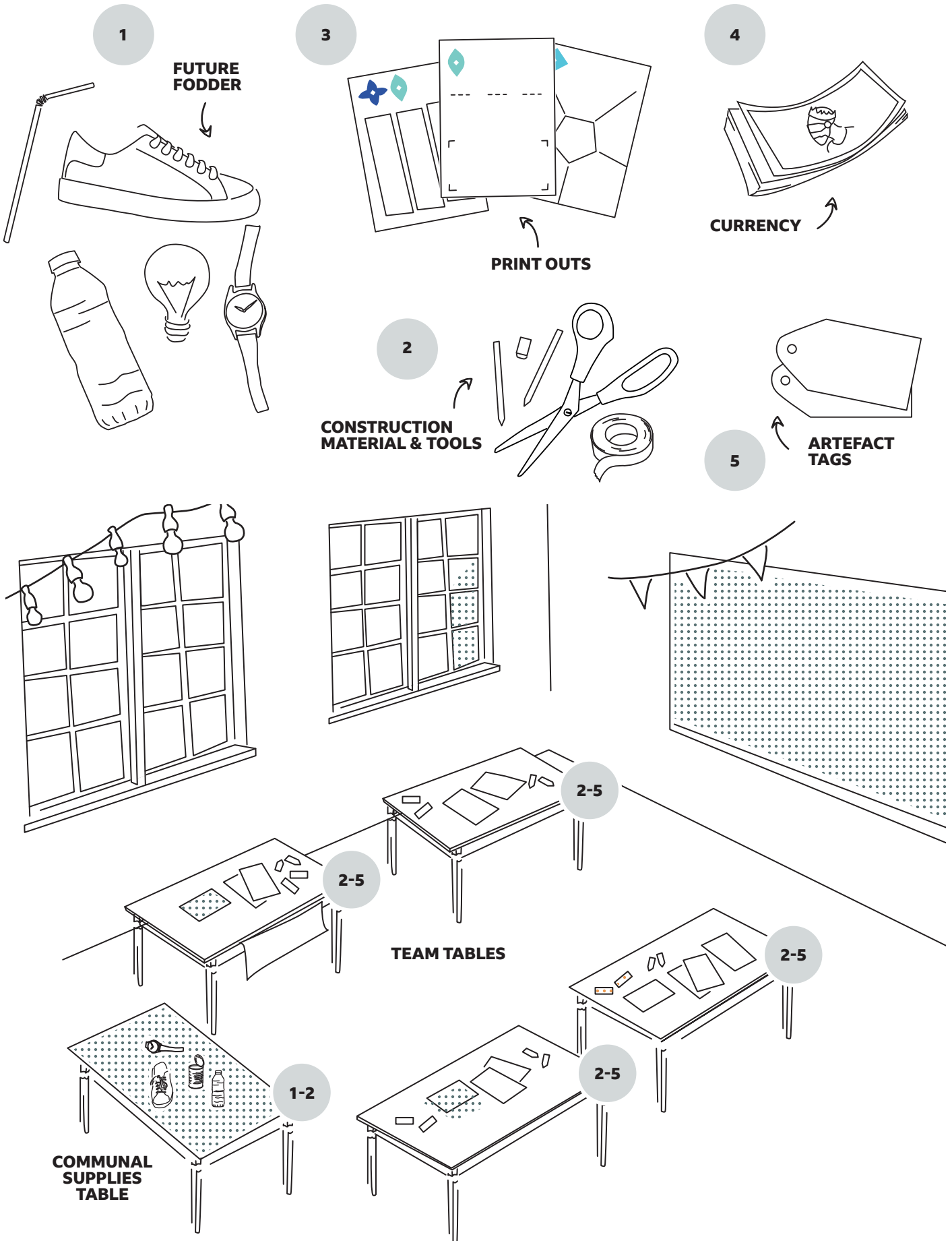

# STRUCTURE

---

Here are the steps and some suggested durations for running a Futures Bazaar. The total time below is 3 hours, which we have done with a group of around 40 adults moving quite briskly. Timings can vary of course, and should be planned according to the type and number of participants.



## STEP 0 WELCOME

As facilitator you explain the event's purpose and outline the agenda.

**5 minutes**



## STEP 1 WARM UP

Teams practice playfully imagining things from alternative futures.

**20 minutes**



## STEP 2 EXPLORE

Teams explore their particular future world by brainstorming its implications.

**15 minutes**



## STEP 3 GATHER

Teams retrieve the materials with which they will create artefacts for their stall.

**5 minutes**



## STEP 4 IDEATE

Teams generate future artefact ideas.

**25 minutes**

## BREAK

Take a break here, or after Step 5 or Step 6, depending on group momentum and energy.

**10 minutes**



## STEP 5 CREATE

Individually or in teams, participants make and label future artefacts for sale.

**30 minutes**



## STEP 6 SET UP

Each team builds and decorates its bazaar stall.

**20 minutes**



## STEP 7 RUN

The group will experience their creation as the Futures Bazaar opens.

**40 minutes**



## STEP 8 TAKE DOWN

Everyone helps tidy and pack up.

**10 minutes**

# PREVIEW OF FINAL OUTCOME

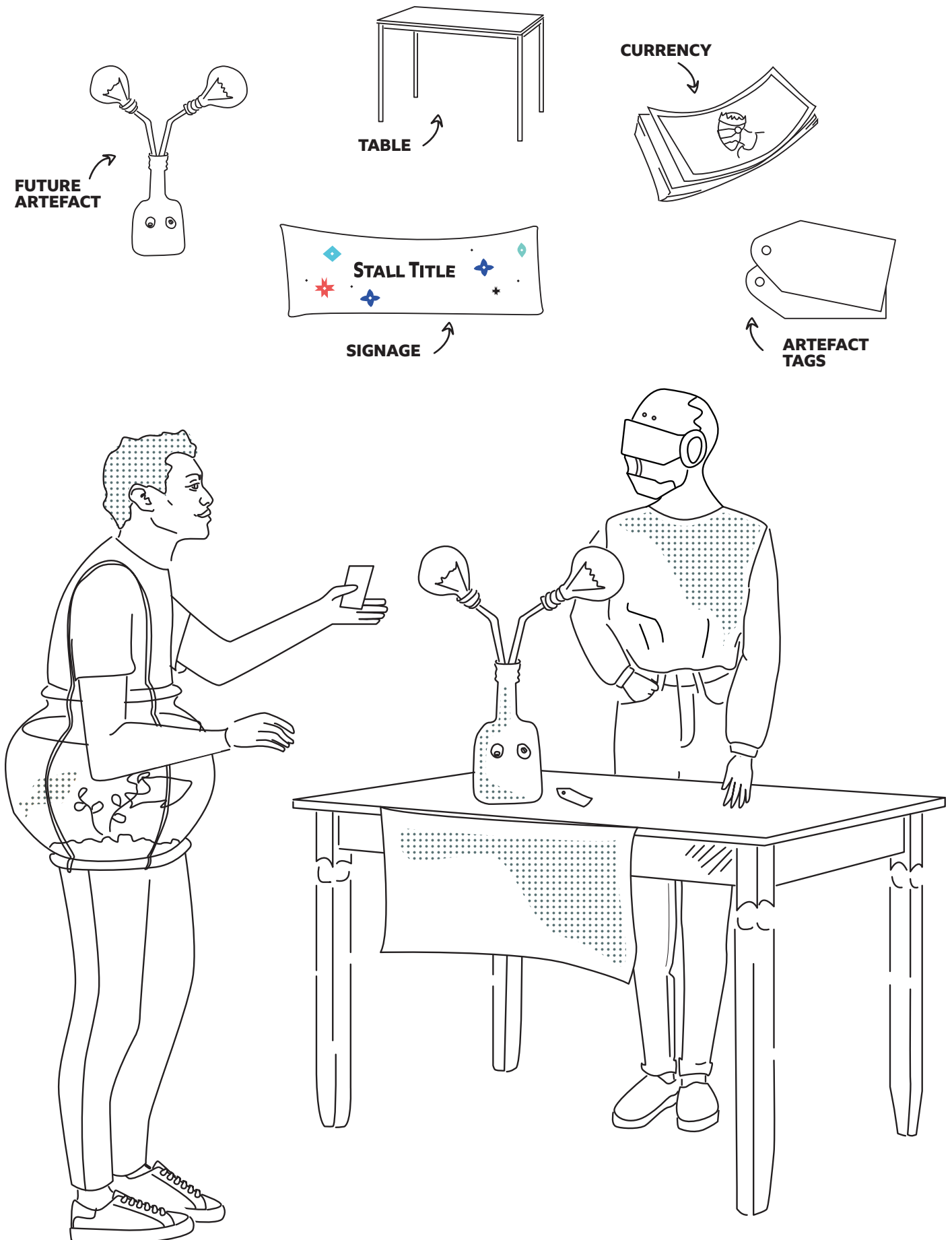

# FACILITATING THE EVENT

---

## SETTING UP

Set up the room, tables and materials before participants get there so that you can dive in to the activity right away. In case attendees may not know each other, consider having nametags available as they arrive. Distribute the printouts etc for each team (indicated in the Materials section) by placing them on their tables.

Pre-fill in the centre of each Explore Sheet (for Step 2) with a different type of Future for each table. This will help expand the Bazaar's explorations in a variety of directions. You could have teams choose their own Future when they reach Step 2, but the Bazaar experience is likely to be more generative and interesting the more divergent the future stalls, so we recommend that the facilitator find a way to ensure diverse Future types across the group.

A communal supplies table accessible to everyone should be designated for construction materials to be shared by the group, such as paper, markers, scissors, boxcutters, tape, glue, string, etc.

Collect the Future Fodder items brought in by participants as they arrive, and pile them in a location where they can easily be retrieved when the time comes.

## FORMING TEAMS

The number and size of teams depends on participant numbers as well as the number of tables at your disposal. One table per team is needed. Again, we recommend 3-4 participants to a table, although pairs can also work.

There may be benefits to larger teams, as four people can perhaps create a larger or more sophisticated stall than two – but these need to be weighed against the benefits of having the same sized participant group distributed across a greater number of teams, and thus the potential for a more multi-faceted bazaar overall.

Individually-created stalls are not recommended as this reduces the teamwork opportunity, and when the bazaar goes live, if a solo shopkeeper goes to look around then their own stall will be unattended.

Decide when teams will be assigned and made known – as participants enter, or after they have all arrived? Also, on what basis – deliberately cross-pollinating, self-selected, or random?

Planning your approach to these logistical matters ahead of time will allow for a smoother on-ramp to the event, so you can all get underway with the Futures Bazaar sooner!





# STEP 0 WELCOME

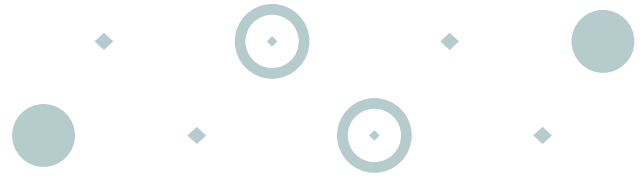

## OBJECTIVE

Get participants oriented and excited.

## SUGGESTED DURATION

5 minutes

1. If you've organised everything as outlined in this Toolkit, then by the time the event begins, the **Slides** together with the one-page Cheat Sheet at the back of this Manual should be set to see you through. These step-by-step Manual instructions are intended to help you visualise and prepare for each stage of the process in advance.
2. The Slides open with the first order of business for the event, a Welcome to participants that sets the mood for the day, briefly outlines the agenda, and reiterates your purpose in gathering together for the Futures Bazaar. (The invitation to participants will have said something about this, but it bears repeating as you begin.) Each slide includes text for you as facilitator to read aloud as the event unfolds.
3. The moment of Welcome is also a chance to fine-tune expectations for the event, according to your group's situation. The role this activity plays might vary depending on whether it's part of an away day for your professional team, a community meetup at your local makerspace, or an experiential futures module within a university design class. Give some advance thought to how you can set everyone up for the most productive use of this opportunity to play and create together.
4. Before proceeding to Step 1 would also be a good time to mention any housekeeping matters. For instance, you might encourage participants to take plenty of photos, or clarify the policy of your event or organisation around permission to post online.

## MATERIALS

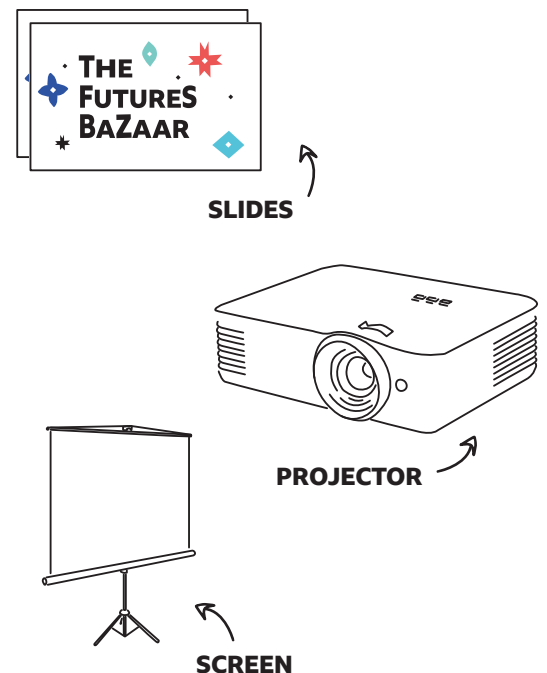



# STEP 1 WARM UP



## OBJECTIVE

Practise imagining futures.

## SUGGESTED DURATION

20 minutes

1. To help get creativity flowing, we start off with a rapid-fire gameplay icebreaker where the most imaginative responses win. This is centrally facilitated by you, so you'll need to keep an eye on the clock, and usher teams through these stages in sync.
2. You will ask each team to find the person whose birthday is coming up next in their group. That person will choose a Future from the Prompt Sheet. Moving clockwise, the next person chooses a Thing. The one after chooses a Theme. Altogether this process should only take a minute.
3. Each player will then take a Warm Up Sheet, and record the prompt on it. Give everyone a few minutes (probably 3–4, but see how they go and use your judgement) to separately and silently make up a description and/or sketch of a “thing from the future” inspired by their team’s prompt.
4. Ask teams to transition into sharing and discussing their responses. These may be funny, weird, scary, or thought-provoking – ask the group to choose its favourite future thing. The sharing and choosing should be capped at about 3–4 minutes.
5. Before doing another round, you might invite one or more teams to share their prompt and favourite artefact response with the room. Ask them to keep it succinct so everyone can hear ideas from as many groups as possible. Highlight whatever was specific about the response that made it a successful answer. You may then invite groups to play a second round, and this time have teams switch roles within groups, so the second player chooses the Future, and so on. Depending on time, and how groups are faring with the activity, you might do a third round before moving on.

## MATERIALS

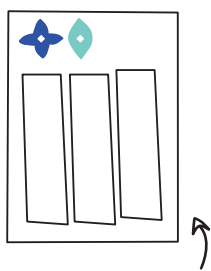

PROMPT SHEET

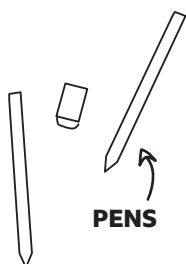

PENS

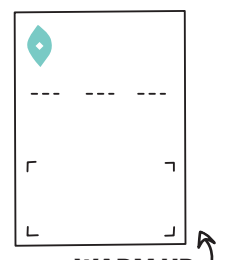
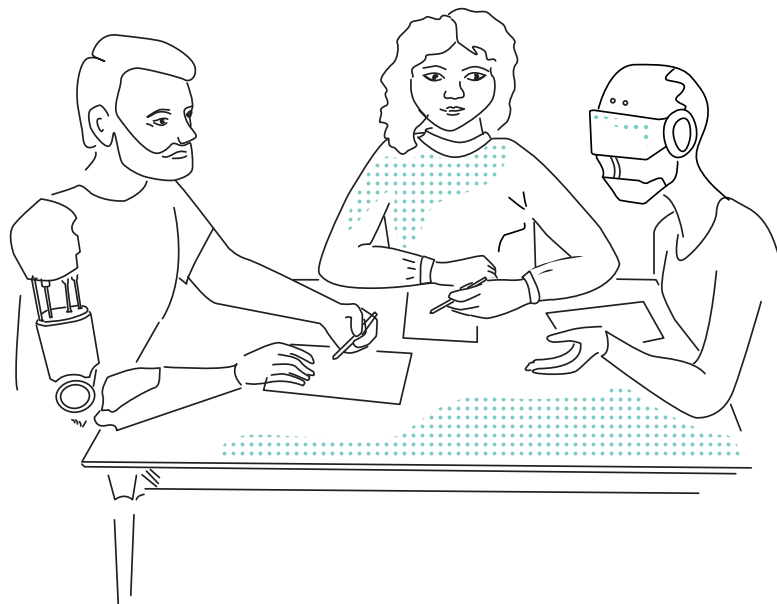

WARM UP SHEET



# STEP 2 EXPLORE

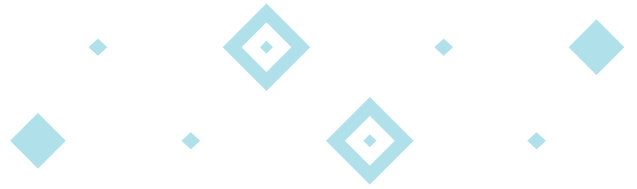

## OBJECTIVE

Teams give depth to their designated future world by expanding on its implications.

## SUGGESTED DURATION

15 minutes

1. Ask each group to take an Explore Sheet and choose a scribe.
2. As a team, have them reflect on their designated Future. They are being invited to look at least a few decades out from now, and imagine that the future that has come about matches the description. As facilitator you might opt to set a specific time horizon for the room at this stage, depending how adventurous you want their thinking to be, such as the year 2050, or 2100. If so, tell them the time horizon and also why you are selecting it. Their task is to think about the following: if this type of future were to come about by that time, what kind of society, technology, economy, environment and politics might we see? Players are invited to be as audacious and creative as they wish – while ensuring that their descriptions align clearly with their team’s particular Future.
3. Team members will take turns adding sentences under each heading. The player whose turn it is chooses which heading they want to focus on, in any order. Later answers should build on earlier ones, and the idea is for the team gradually to paint a fuller picture of how their version of this future world looks. Responses should be written from the vantage point of the assigned future. For example - a “Lonely” Future, in the year 2100. How is this quality reflected in each factor? Social: “People have become increasingly isolated from each other, and etiquette has developed to avoid social interaction. Meeting with a crowd has become a subversive act.” Technology: “The social media bubble has burst and nobody uses it. Noise-cancelling technology has become ubiquitous.” And so on.

## MATERIALS

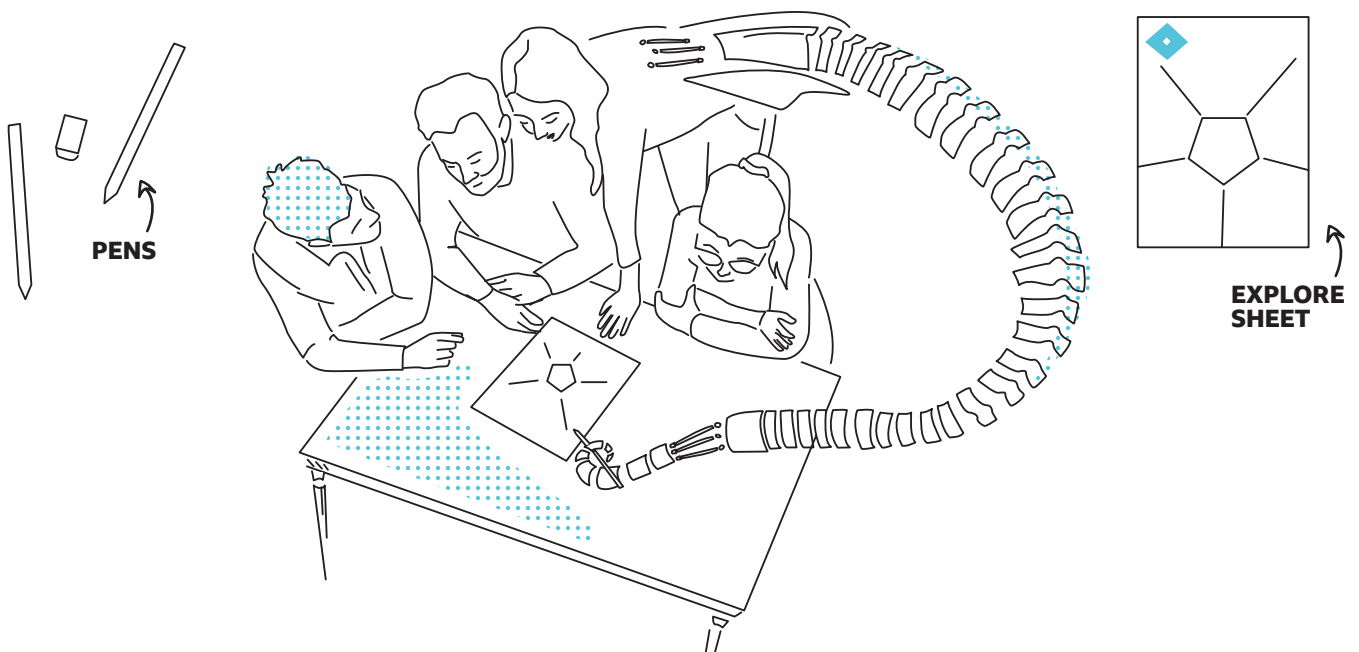



# STEP 3 GATHER

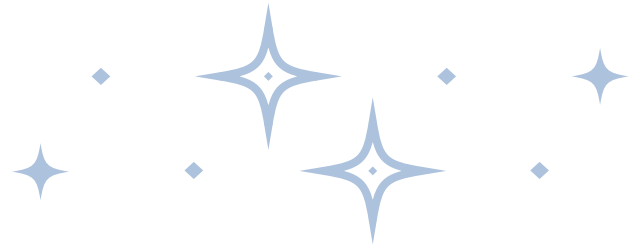

## OBJECTIVE

Teams retrieve the materials which they will transform into future artefacts.

## SUGGESTED DURATION

5 minutes

1. This step should move at high speed, taking no longer than five minutes. It is meant to raise energy levels as well as offer key inputs into the design process, as folks prepare to work out what they are going to make and sell at their Bazaar stall.
2. Taking turns, team members will now go and source one item at a time from the Future Fodder pile – the “raw materials” that you collected from them as they arrived. This is the stuff they will use to create future artefacts for the stall. Advise participants to move briskly but at a safe speed – walk, don’t run – but don’t take too long, so that they get back to their table quickly and the next person can go.
3. Without overthinking it, they are invited to bear the previous step in mind when making selections. Are there any Future Fodder items that evoke a feeling of their particular future?
4. Repeat the process until each team has enough items to work with (perhaps 7–8 items) or until time is up. You may distribute any remaining items at random as “bonuses” to teams after this.

## MATERIALS

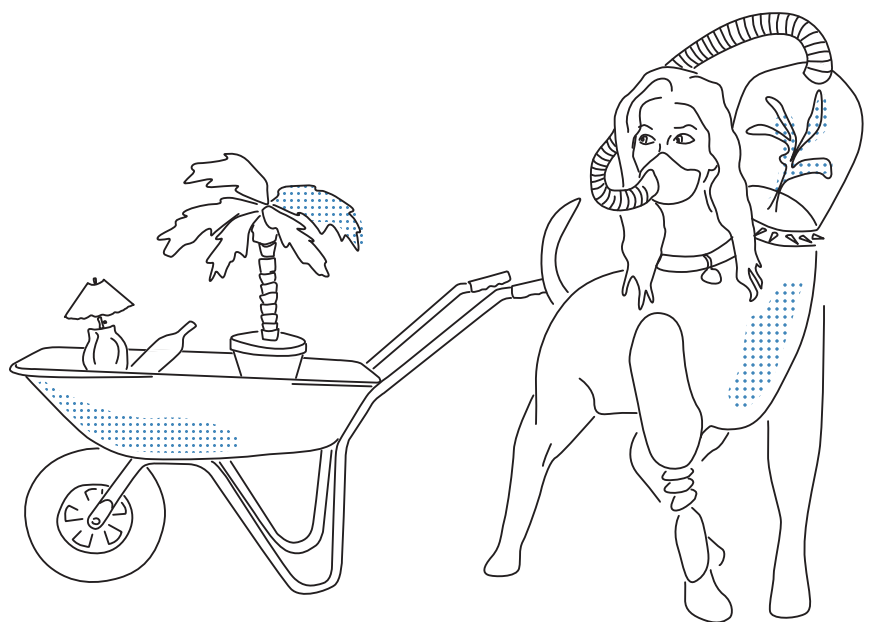
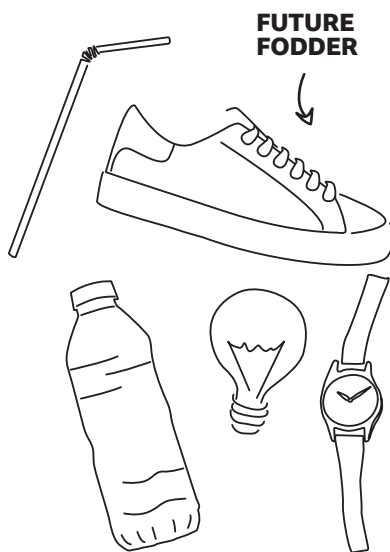





# STEP 4 IDEATE

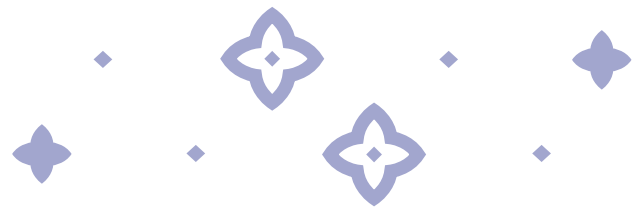

## OBJECTIVE

Generate future artefact ideas.

## SUGGESTED DURATION

25 minutes

1. This ideation step is structured like the Warm Up, with players generating future artefact ideas by combining a Future, a Thing and a Theme. But this time they'll use physical Future Fodder items as part of each prompt.

Players have already been assigned a Future for their stall. Taking each of their team's Future Fodder items in turn as the Thing at the centre of a prompt, they will now cycle through different Themes from the Prompt Sheet and ask: how might this item be reimagined and remade as a distinctive artefact from their particular future?

2. Teams are now tasked to brainstorm as many ideas as they can for each item, and consider the potential for hacking and combining objects too. At this point teams are responsible for moving at their own pace, and coming up with as many ideas as they can within the timeframe you provide, rather than being synced up round by round, so give the room occasional reminders about the time remaining as it ticks down.

## MATERIALS

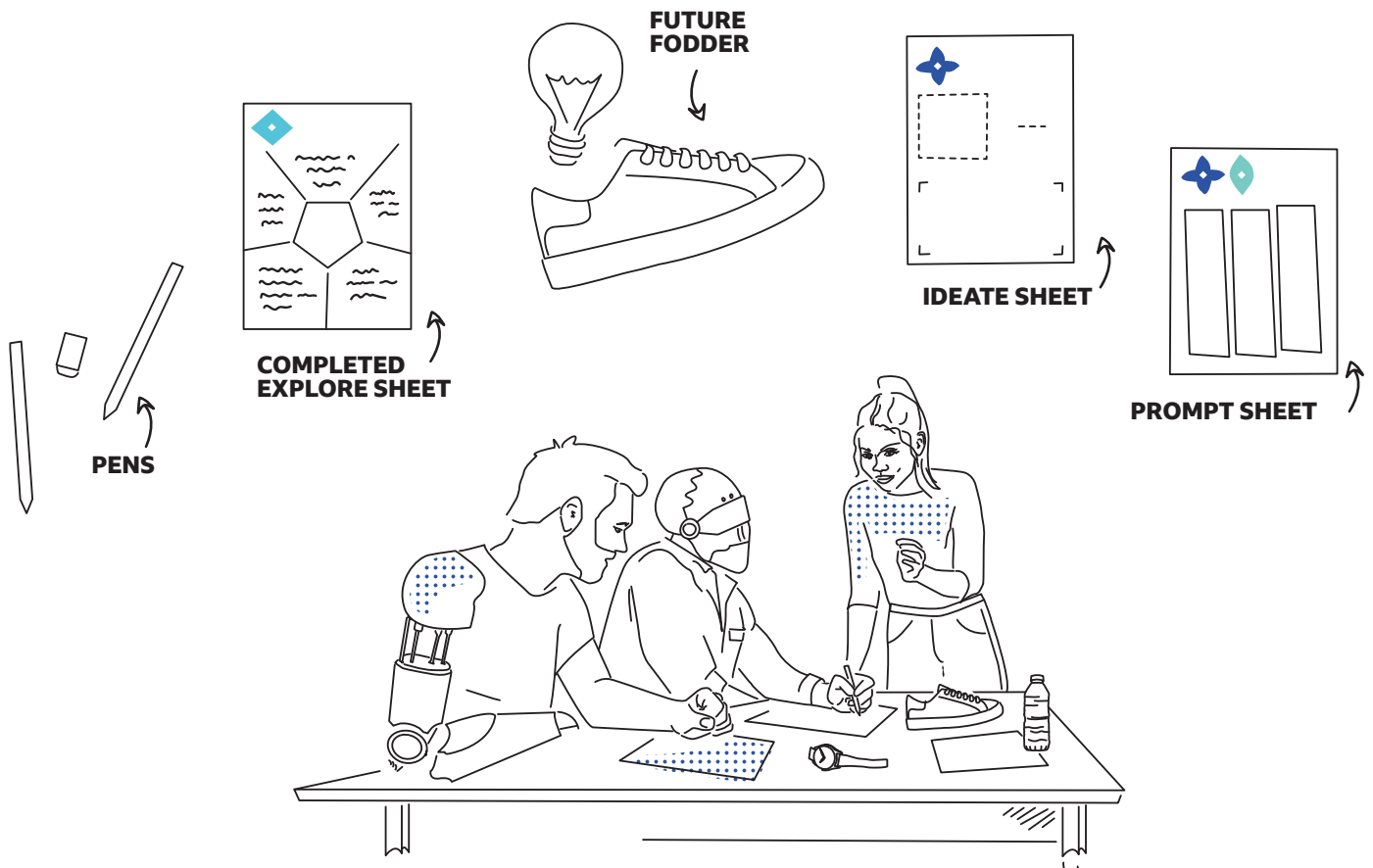



# STEP 5 CREATE

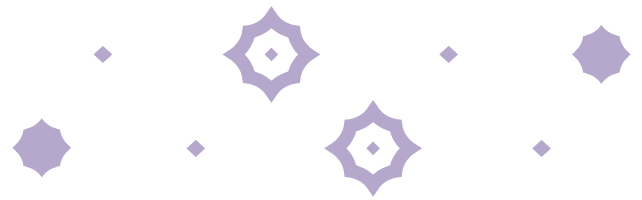

## OBJECTIVE

Make and label future artefacts for sale.

## SUGGESTED DURATION

30 minutes

1. This stage calls for teams to start by picking their best ideas, considering how the candidate artefacts would, individually and as a set, evoke their designated future. Again, this step is time-boxed and self-paced, so teams should be encouraged to make their decisions quickly, and move on to actual making within five minutes or so, in order to avoid losing too much precious fabrication time – which will pass quickly.
2. As they begin making their selected future artefacts, you should highlight that it is their choice whether to collaborate or work in parallel. But by the end, participants should have produced at least 1–2 artefacts per head.
3. Participants will use Future Fodder, glue, paper, scissors etc to create, alter, mutate and merge items. Or, keep them close to the way they came, and transform their meaning by using the Artefact Tags.
4. A final future artefact should let a visitor grasp the story behind it, and how it evokes the team's future. Each needs its own Tag written from the perspective of the world in which it is for sale. Encourage participants to have fun with the possible stories of their artefacts, including the ways that objects may be seen from the vantage point of the future that their stall exists in. For instance, something very commonplace and unremarkable in the present could be highly precious in a certain kind of future scenario. Or the opposite might be true.

## MATERIALS

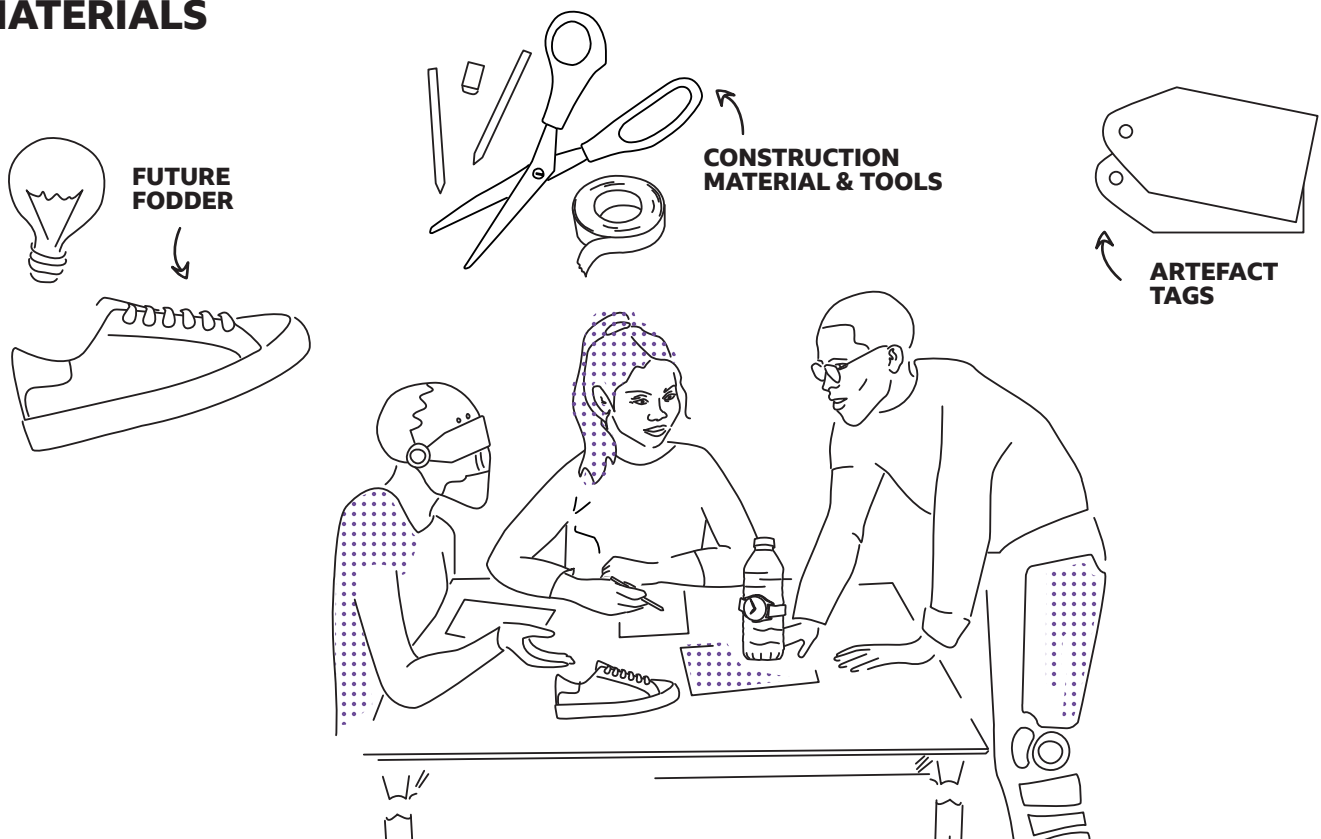



# STEP 6 SET UP

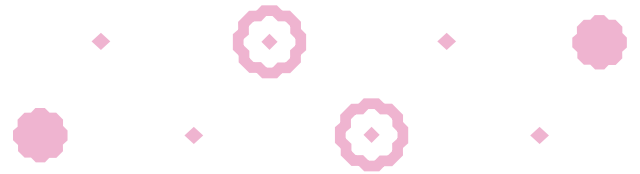

## OBJECTIVE

Teams build their stalls.

## SUGGESTED DURATION

20 minutes

1. First, teams will create a Stall Banner as a centrepiece for their display. The branding should clearly describe and “sell” their type of Future and its special merchandise. Short, attention-grabbing copy will help convey what the collection of artefacts is about.
2. Teams can deploy any extra materials in decorating the stall. This is an interdimensional multi-futures marketplace, so they should feel free to really let their creativity run wild!
3. A bazaar is nothing without its merchants and customers. You’ll remind participants that they should prepare to be in character, and when the bazaar launches, they’ll have a chance to play on both sides of the stall. As merchants, what lines might they say to attract customers? What materials could be used to craft future-suitable costumes?

## MATERIALS

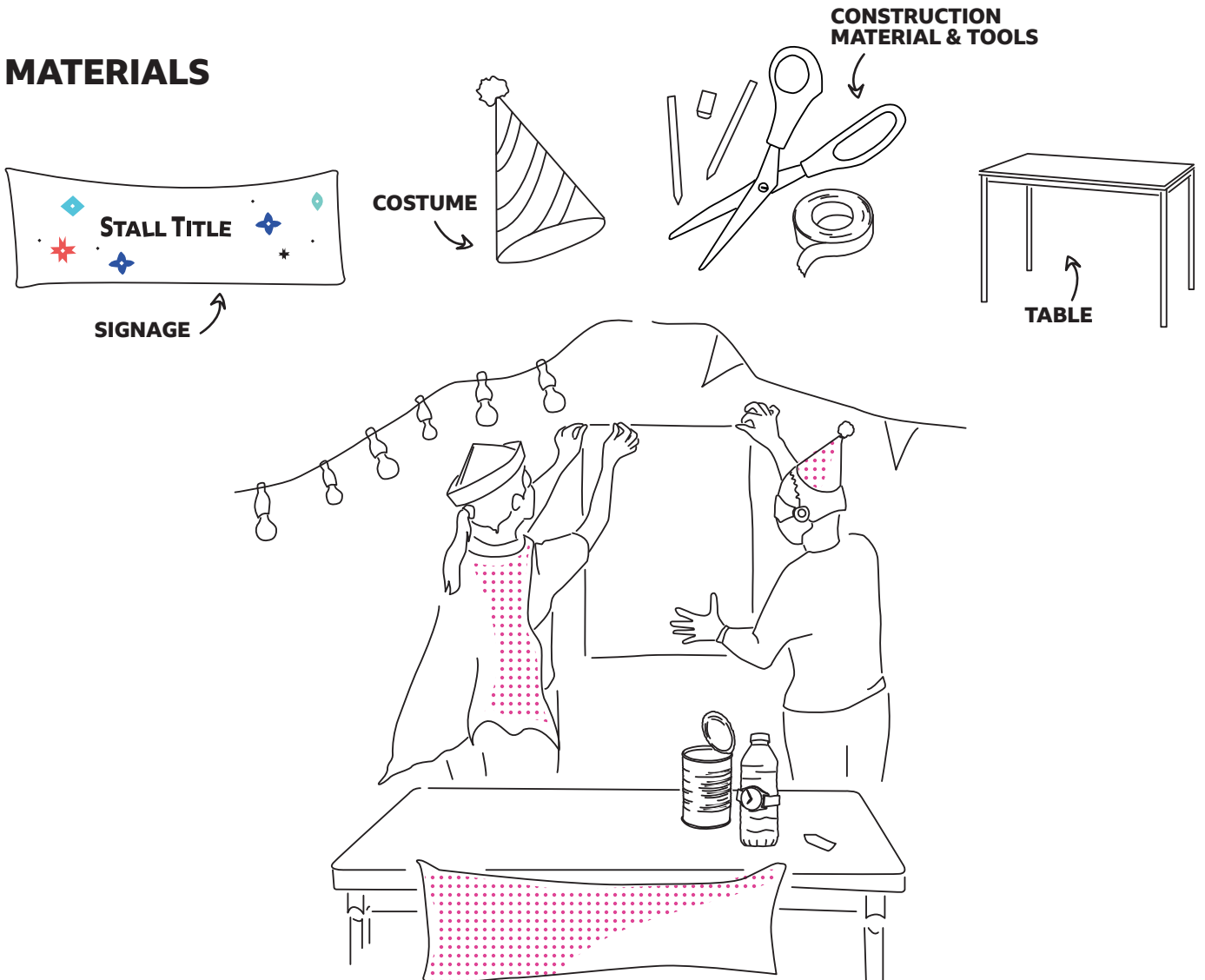

# STEP 7 RUN

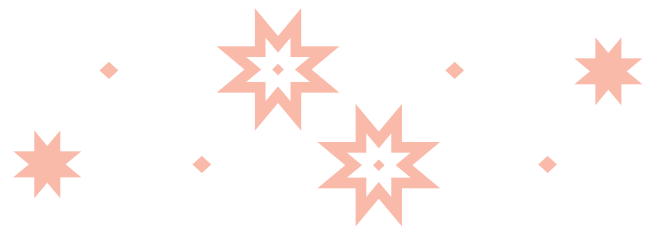

## OBJECTIVE

Everyone experiences their collective creation.

## SUGGESTED DURATION

40 minutes

1. As facilitator you will divide the runtime in half, and invite folks to swap roles halfway, with an appropriate time warning given to help the group pace themselves.
2. Before the Bazaar launches, participants should be aware that everyone will get to play on both sides of the stall, taking turns being merchants and customers. At least one team member should always be staffing the stall (two is best) while others roam as customers, currency in hand.
3. Remind “merchants” to stay in character at all times and make every effort to “sell” their artefacts. You will ask “customers” to keep an eye out for any artefacts that excite them, scare them, or make them laugh, and to leave some currency by the most fun and thought-provoking ones they find.
4. This is also a good moment to remind people to take pictures and videos to post on social media and share with the wider community using the #FuturesBazaar hashtag!
5. Note: The format described in this Manual assumes the default arrangement – that event participants / Futures Bazaar co-designers will be the only ones in the room for this step. However, in some circumstances a variation to consider at the planning stage might be to schedule the running of the Bazaar itself for a particular window, so as to be able to welcome additional visitors (who would need to be briefed ahead of time, and then given some currency of their own on arrival), thus allowing a larger group to join in the fun.

## MATERIALS

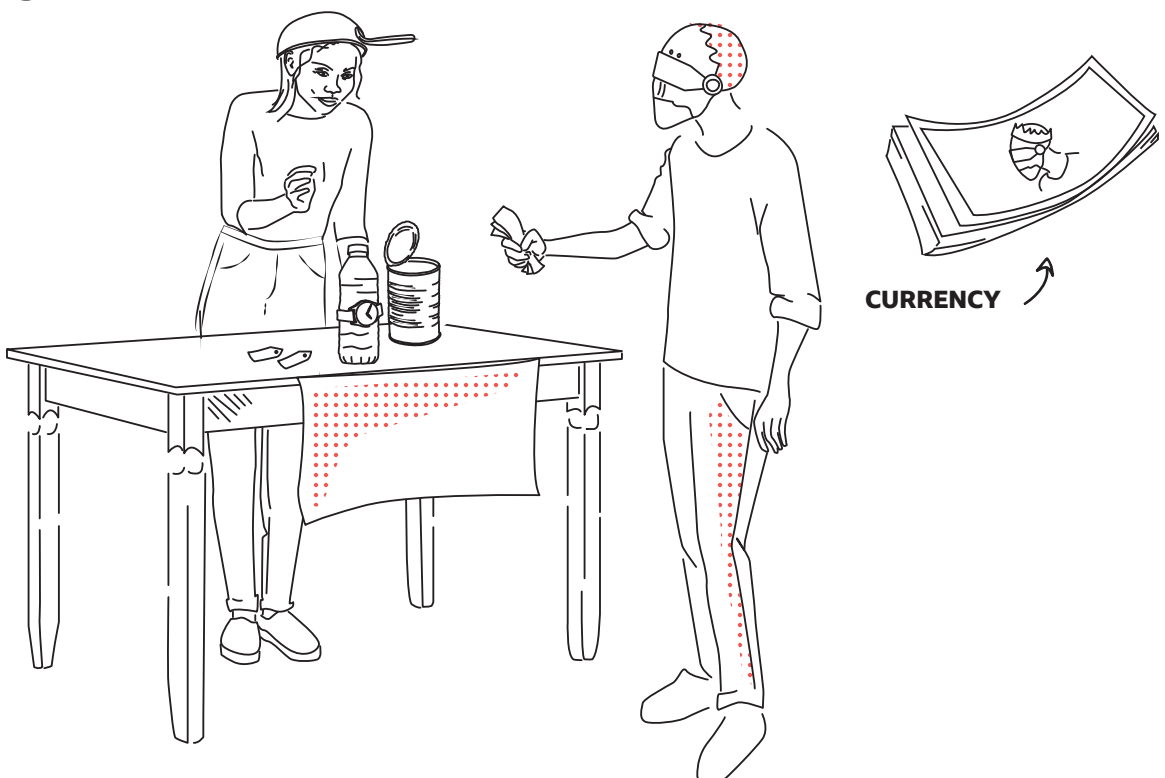



# STEP 8 TAKE DOWN

## OBJECTIVE

Leave the space the way you found it.

## SUGGESTED DURATION

10 minutes

1. Ensure that everyone has had a chance to document their stalls and individual artefacts before giving the green light to start tidying up. The group might attend especially to artefacts that received a large tally of currency “votes”.
2. An optional stage that could be added here, with advance planning of course, might be some group “awards” or recognition for particularly skilful artefact or stall designs, enthusiastic roleplay, etc.
3. Check if anyone wants to keep any of the artefacts and take them home.
4. Everything else should be disposed of, making sure to recycle all recyclable materials.

## MATERIALS

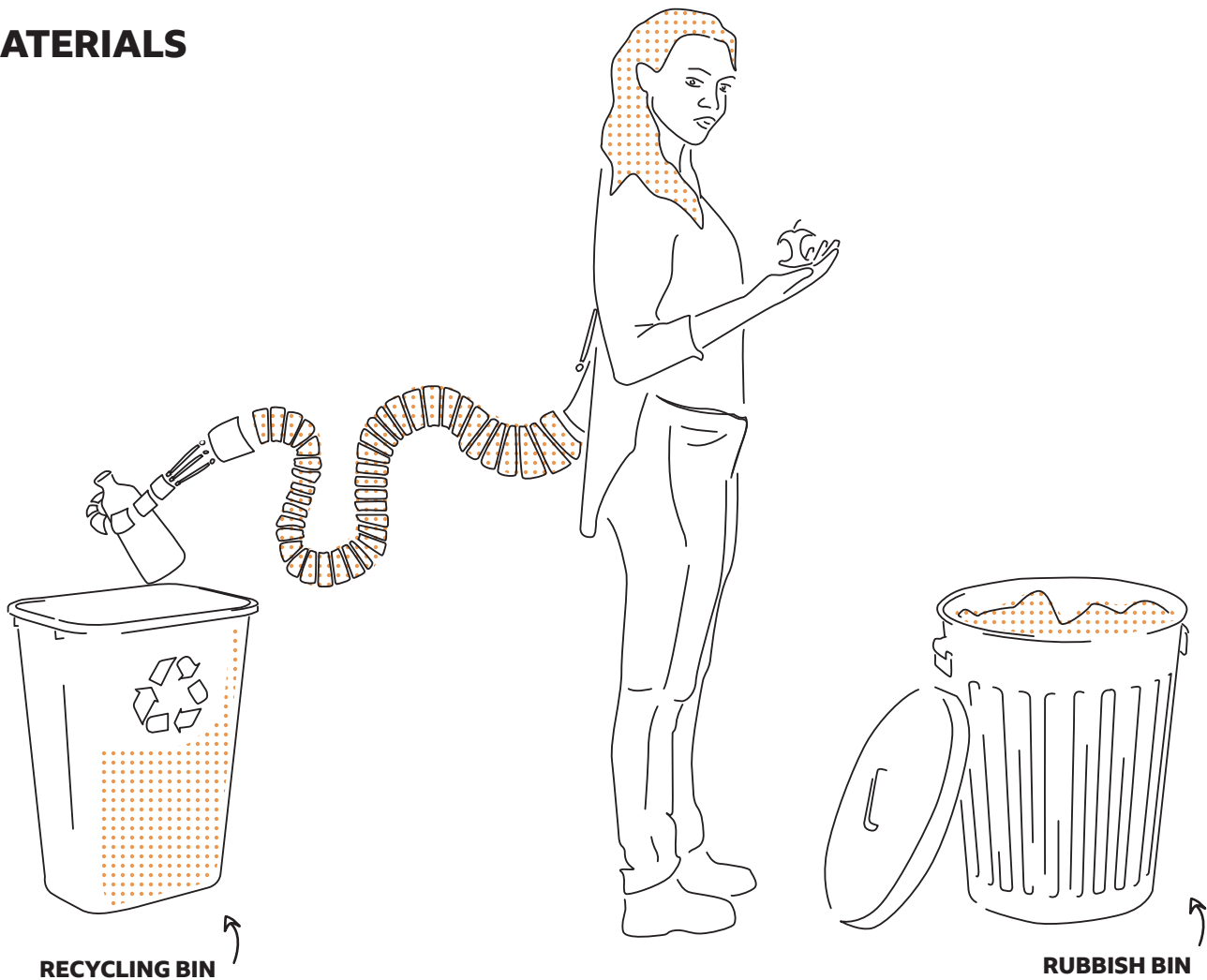

# SHARING OUTCOMES

---

## #FUTURESBAZAAR

The Futures Bazaar is a multi-dimensional entity. On one hand, there is *your* particular event, in all its glorious futuristic weirdness. But there is also the much larger, collective Futures Bazaar, an imaginary place across time and space, made up of *all* the iterations that have happened in the past and will happen in future.

So how to capture and share the outcomes of your event? Once a bazaar is over, it's over, and you'll be glad to have good documentation of what happened. So make sure you take lots of pictures! Encourage participants to do so as well.

When photographing particular objects, making sure that artefact tags are legible may help viewers better understand what they are about. Similarly, for pictures at the scale of of a stall, we would recommend trying to include the stall name/banner for context.

Before posting, ensure that people have given permission for any photos or video where they can be identified to be used; or replace faces with emojis.

A key aim of this initiative is to collectively make a wider range of futures more imaginable and accessible. As more and more folks run their own Futures Bazaar, it will leave behind a growing commons of imaginings, questions, and provocations about possible worlds. To contribute to this shared resource of public imagination, post your best pictures and videos on social media using #FuturesBazaar.

# BACKGROUND

---

## EXPERIENTIAL FUTURES

Experiential futures is a range of practices for making hypothetical futures available in tangible, performative, interactive and playable forms. These strategies in arts, media, design and gameplay aim to make it easier for humans to grapple with their long-term and large-scale prospects, by making them more richly imaginable and discussable. Further reading: [Candy and Dunagan, The Experiential Turn](#).

## PARTICIPATORY DESIGN

Participatory Design is an approach to design that seeks to actively involve key stakeholders – partners, colleagues, users, citizens – in the work of sense-making, challenge-framing and idea-generating. Participatory design processes are often used to enable higher-quality conversations between the different stakeholders, and to facilitate joint identification and navigation of latent needs, fears, and desires, and the possibilities for addressing them. Further reading: [Sanders, Perspectives on Participation in Design](#).

## FUTURES STUDIES

Futures studies or strategic foresight is a transdisciplinary field, dating back several generations, which is oriented to helping organisations and communities map their possible, probable and preferable futures in order to shape change in desired directions. Further reading: [World Economic Forum, What Futures Studies Is, and How It Can Improve Our World](#).



# AUTHORS

---

## STUART CANDY

Stuart Candy, Ph.D. (@futuryst) is a pioneer of experiential futures practices for amplifying collective imagination and deliberation in diverse settings, from design studios, boardrooms, and UN summits, to festivals, museums, and city streets. A frequent advisor to strategic initiatives in foresight, storytelling, leadership, science, and the arts, he has worked with large technology companies and independent artists; city, state, and national governments; and organisations including the BBC, The New York Times, National Film Board of Canada, Smithsonian Institution, US Conference of Mayors, and NASA JPL. He is a Berggruen Fellow at the University of Southern California, Director of Situation Lab, Associate Professor of Design at Carnegie Mellon University, and a Fellow of the World Economic Forum and the Long Now Foundation. His previous publications include the long-running *Sceptical Futuryst* blog, the edited collection *Design and Futures*, and acclaimed card game *The Thing From The Future*.

## FILIPPO CUTTICA

Filippo Cuttica (@filippocuttica) is a designer, artist and futurist working between critical speculation and responsible innovation. He focuses on the ethical, societal and environmental implications of technology and has advised clients such as, the European Commission, Google, the UK Health Security Agency, Samsung and Panasonic. At the BBC, as the UX Principal for Ethical and Cultural Experiences, he introduced practices aimed at a deeper engagement with the moral dimensions of design, and pioneered experiential futures methods to drive ethical enquiry and debate. He's a visiting faculty at various universities around the world, teaching courses such as *Future Casting* at the Copenhagen Institute of Interaction Design, and *Designing for Responsible AI* at Elisava, Barcelona. He is a co-founding member of the art group IOCOSE, whose work has been exhibited at Transmediale (Berlin, 2013), OGR Torino (2018, 2021), Fotomuseum Winterthur (Switzerland, 2017) and The Photographers' Gallery (London, 2016, 2018).

# ACKNOWLEDGEMENTS

---

## FROM THE AUTHORS

We would like to express our sincere thanks to everyone who contributed to this project, which was an unusually long time in the making due to the Covid-19 pandemic.

The BBC GEL team worked tirelessly in supporting us to bring the Futures Bazaar toolkit to fruition. Callum Peters has been a vital ambassador for this public version since day one. Marie Rasmussen brought wonderful illustrations and input into the overall visual design. Ed Goldman helped develop and finalise the visual language and layout. Andy Nott generously provided oversight to guide its passage to publication.

Jane Murison and Tamar Gur, then Heads of Design at BBC, sponsored the Futures Bazaar's first incarnation at Albert Hall Manchester back in 2019 (see [bbc.co.uk/gel/features/futures-bazaar](https://bbc.co.uk/gel/features/futures-bazaar)). A passionate group of then-trainees at BBC UX&D poured their energies into that original experiment: Chanelle Pal, Dave King, Jack Solomon, Lydia Laitung, Nicolas Jones, and Sarrah Mohammed.

At the event, the whole BBC UX&D team, numbering in the hundreds, made wonders happen with our initial process design. Not long after, participants in Stuart's undergraduate design futures course at Carnegie Mellon, ably supported by teaching assistant Isha Hans, brought a Futures Bazaar of their own to life. We are grateful to both groups for their playfulness, creativity, and feedback.

Many thanks also to our partners Aimee Brewerton and Ceda Verbakel; to Adriana Sanchez for timely visual input; to USC Situation Lab director Kiki Benzon for unwavering support; to longtime Sitlab collaborators Elliott Montgomery and Chris Wuebken for early inspiration; and lastly, to the late and much missed co-founder of Situation Lab and co-creator of The Thing From The Future, Jeff Watson. This offering to public imagination is dedicated to his memory.

# FACILITATOR'S CHEAT SHEET

---

## IN ADVANCE

- Find a suitable space**

This could be a room or an open area. You'll need a table for each team, the materials you're working with, and a projector or monitor to show slides.
- Set a timeslot and plan rough step-by-step durations**

Probably 3–4 hours, give or take.
- Invite and confirm participants**

Make the event purpose clear. Include the request to bring in Future Fodder on the day, including advice for what to favour or avoid.
- Prepare Printouts**

Number required varies – see Materials. Warm Up Sheets, Explore Sheets, Ideate Sheets, Prompt Sheets Artefact Tags, and Bazaar Currency. Pre-populate Explore Sheets with diverse types of futures if desired.
- Secure Basic Materials**

For example, pens, markers, paper, scissors, boxcutters, tape, glue, etc. Additional construction and decoration materials are optional but may prove helpful.
- Name Tags** (optional)

Provide name tags if people do not already know each other.
- Reminder** (optional)

Send out a reminder close to the event, reiterating the request for each person to bring Future Fodder items, and additional construction materials if they have them.
- Music** (optional)

Organise background music to play during the event.

## ON THE DAY

- Set up the room**

Set up computer and projector with Slides. Set up team tables and space for materials, including a communal supplies table for shared construction and decoration materials. Distribute printouts, pens and markers.
- Greeting arrivals**

Say hello as people arrive, and provide name tags if applicable. Gather Future Fodder from participants as they enter.
- Seat people at tables with their assigned teams**

One team per stall; usually 3–4 people per team.

- Double check your planned step-by-step durations**

You can also make small adjustments throughout as needed.
- Step 0. Welcome** : \_\_\_\_ minutes  
Read out text from Slides to guide participants through the event. Remind them about any applicable policy around photos and permissions to post online. Encourage lots of documentation.
- Step 1. Warm Up** : \_\_\_\_ minutes  
This first step demonstrates a key process, so it is centrally run, with you as the facilitator guiding everyone through each stage in sync.
- Step 2. Explore** : \_\_\_\_ minutes  
This might be the first step when you play background music while teams are working.
- Step 3. Gather** : \_\_\_\_ minutes  
High speed (but safe) selection of Future Fodder items from the pile; one member of each team at a time, one item per person.
- Step 4. Ideate** : \_\_\_\_ minutes  
This is a time-boxed activity; teams are responsible for their own progress and pace.
- Break** : \_\_\_\_ minutes  
Here is a suggested spot for a break, but you may decide to do it sooner or later than this.
- Step 5. Create** : \_\_\_\_ minutes  
Again, this stage is time-boxed and self paced. Teams choose whether to co-create or work as individuals in parallel, but by the end they should have produced at least 1–2 artefacts per member.
- Step 6. Set Up** : \_\_\_\_ minutes  
Encourage people to decorate their stalls and adorn themselves according to their theme.
- Step 7. Run** : \_\_\_\_ minutes  
Divide the bazaar runtime in half, and make sure people get to take turns being merchants vs visitors. Swap halfway.
- Step 8. Take Down** : \_\_\_\_ minutes  
Invite people to take home what they would like, and recycle anything you can.

## AFTERWARDS

- Contact people to thank them for participating.
- Share documentation using #FuturesBazaar
- Feel free to share with us what you did, how it went, and any feedback or suggestions for future editions!



# ***THE FUTURES BAZAAR***

A PUBLIC IMAGINATION TOOLKIT

**B B C**

 **SITUATION LAB**



**WELCOME**  
**TIME TRAVELLERS**



#FuturesBazaar

# WHAT IS THE FUTURES BAZAAR?

---

**The Futures Bazaar is a playful process for bringing alternative futures to life.**

As a group, we are going to try thinking about different futures through physical artefacts.

We're here to imagine together, transforming mundane materials found in the present into objects from a diverse set of "what ifs".

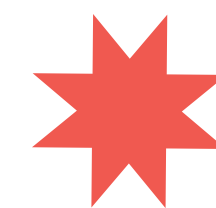
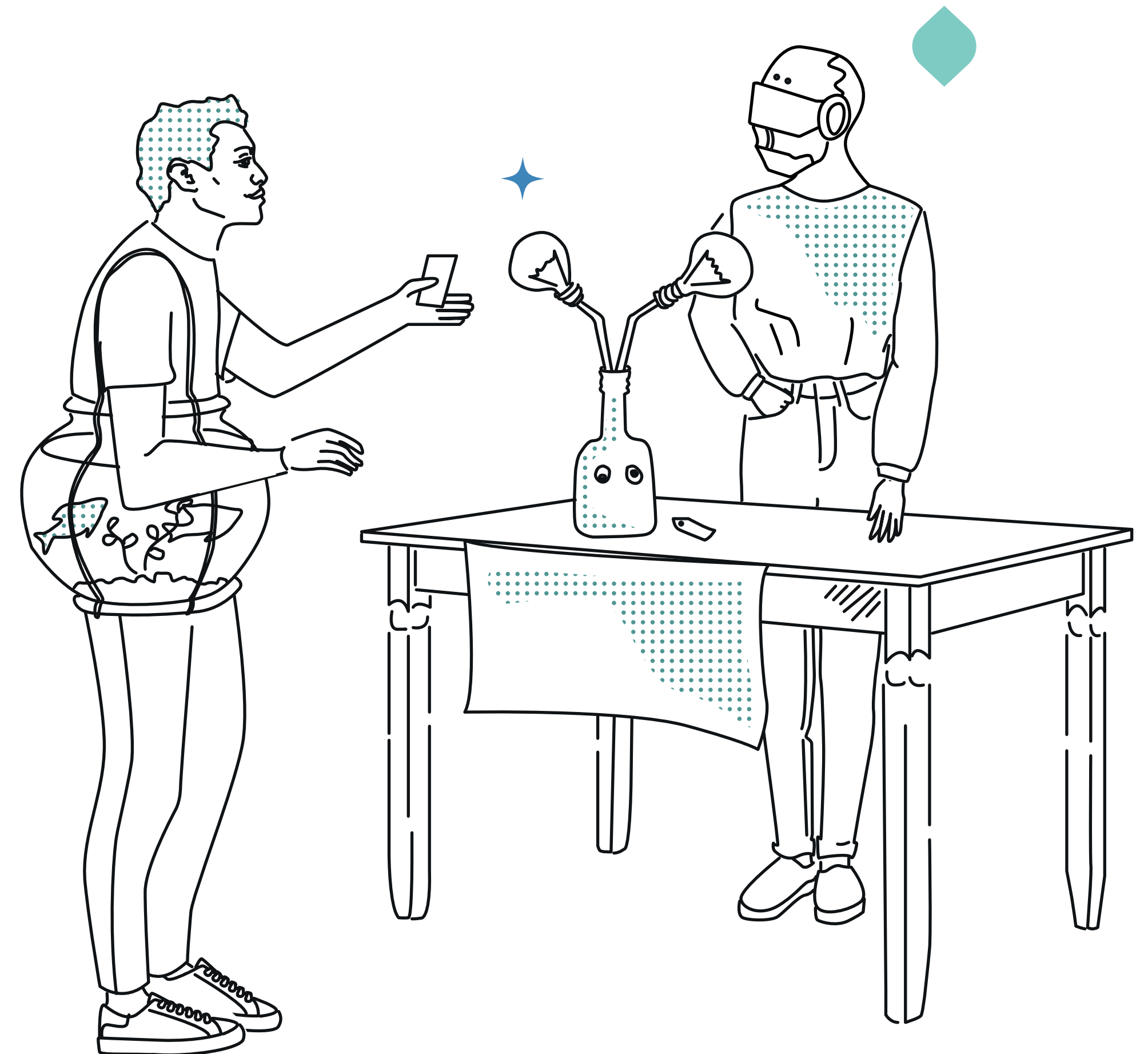

# WHY ARE WE DOING IT?

---

## **Play is a powerful way to hone collective imagination – a key to shaping better worlds.**

Just as you might travel to different places in order to have new experiences and see how others live, creating a Futures Bazaar is a way to journey into each other's imaginations.

This could be an on-ramp into getting more comfortable with some of the approaches and methods of alternative futures/foresight as a field.

Or maybe, we'll just have some fun making weird memories together, while incidentally also lowering the bar to thinking more systematically about possible times to come.

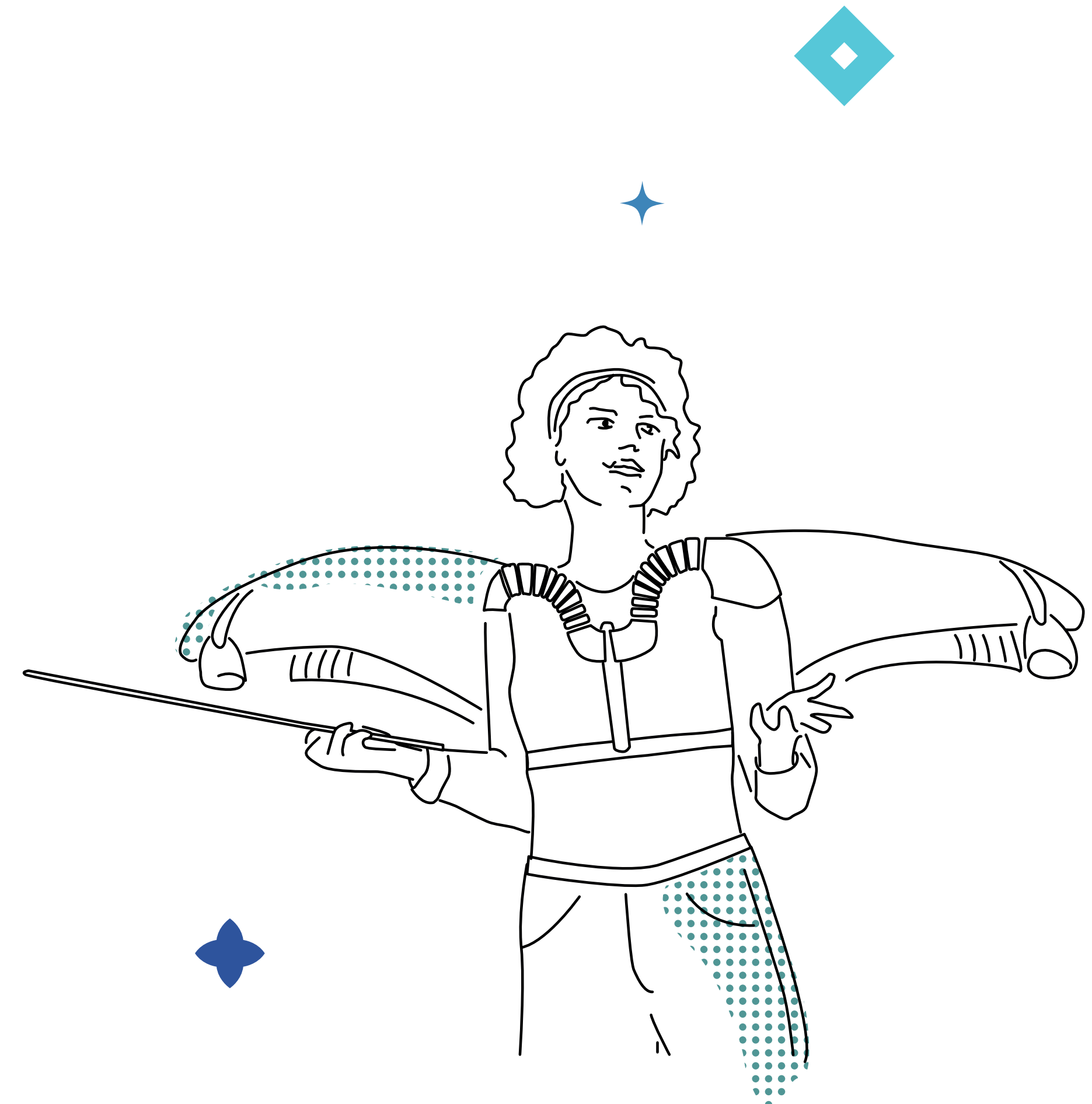



# HOW WILL WE DO IT?

---

 **STEP 1  
WARM UP**

 **STEP 2  
EXPLORE**

 **STEP 3  
GATHER**

 **STEP 4  
IDEATE**

 **STEP 5  
CREATE**

 **STEP 6  
SET UP**

 **STEP 7  
RUN**

 **STEP 8  
TAKE DOWN**

# WHAT DO WE NEED?

---

**We're going to use a few things along the way. We'll tell you what's needed step by step – but here's a quick overview.**

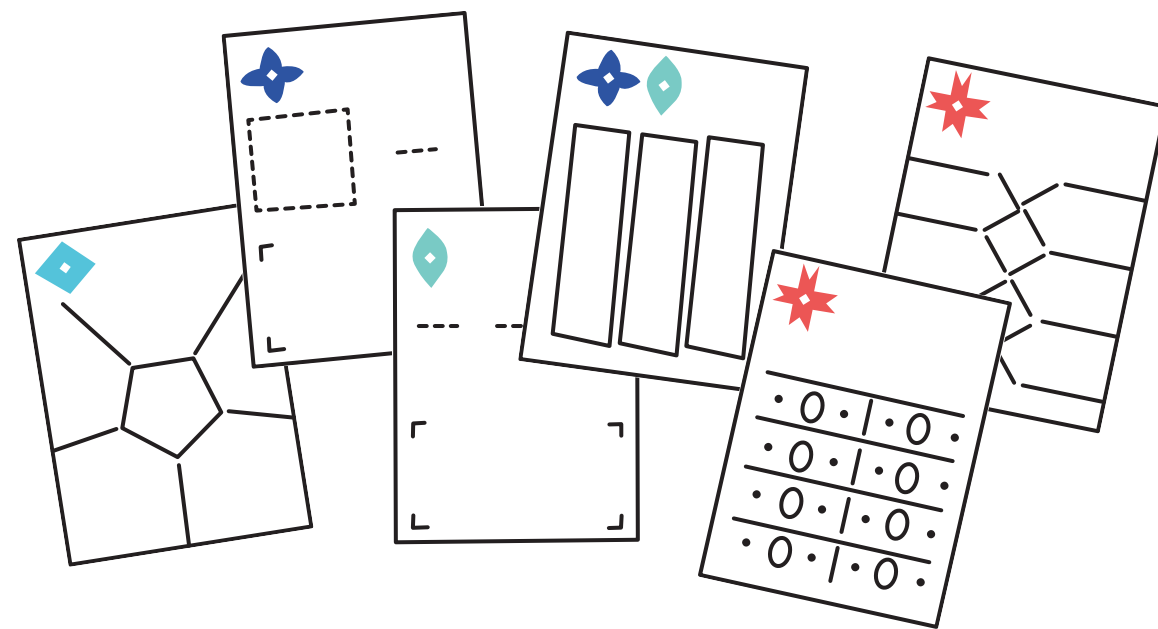

## PRINTOUTS

These will be needed for some steps in the process, and should already be on your table.

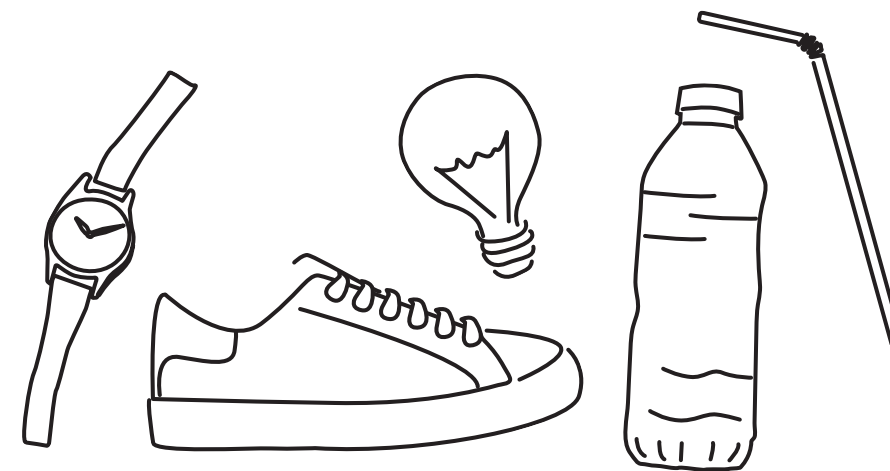

## FUTURE FODDER

These items, collected with your help, are to be transformed into future artefacts. These will be brought into play at the right moment.

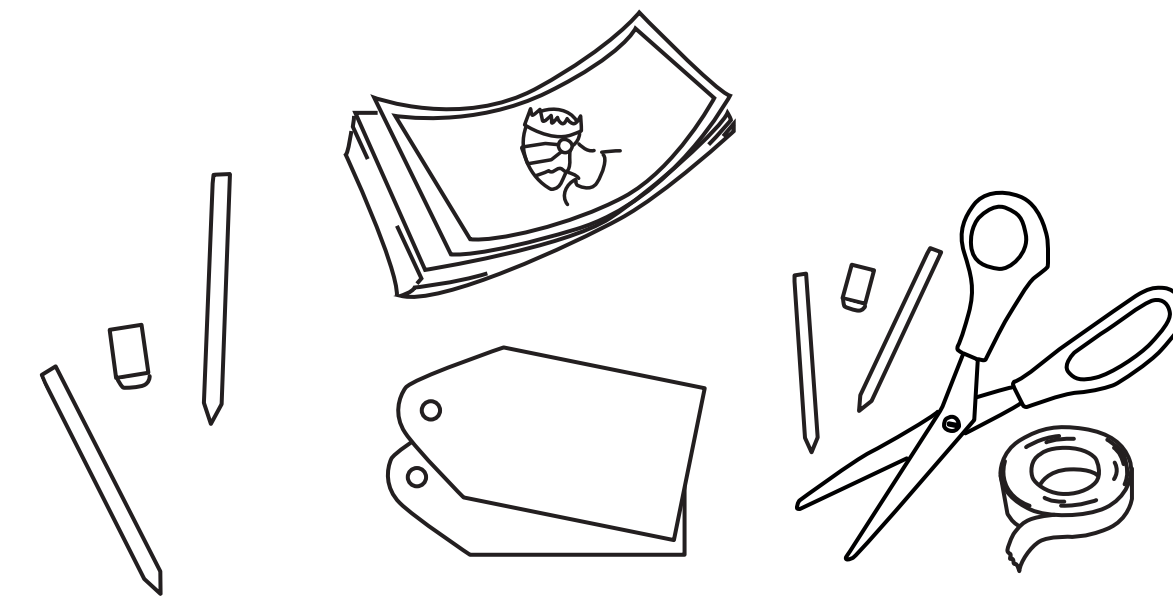

## ADDITIONAL MATERIALS

Pens, paper, glue and other items are provided to help you along with the process.



# STEP 1 WARM UP

## Objective

Practise imagining things  
from alternative futures

# STEP 1 WARM UP

- Each person, take a Warm Up Sheet.
- Find the person in your team whose birthday is coming up next: they should choose a Future from the team's Prompt Sheet. Moving clockwise, the next person chooses a Thing. The one after chooses a Theme.
- Each person, record the prompt on your Warm Up Sheet, and spend a few minutes separately and silently making up a description and/or sketch of a "thing from the future" inspired by it. Try to be as specific as possible in what you imagine!
- When instructed, transition into sharing and discussing your responses. They may be funny, weird, scary, or thought-provoking – which is the group's favourite future thing?
- We might do another round or two to get the hang of it.

## MATERIALS

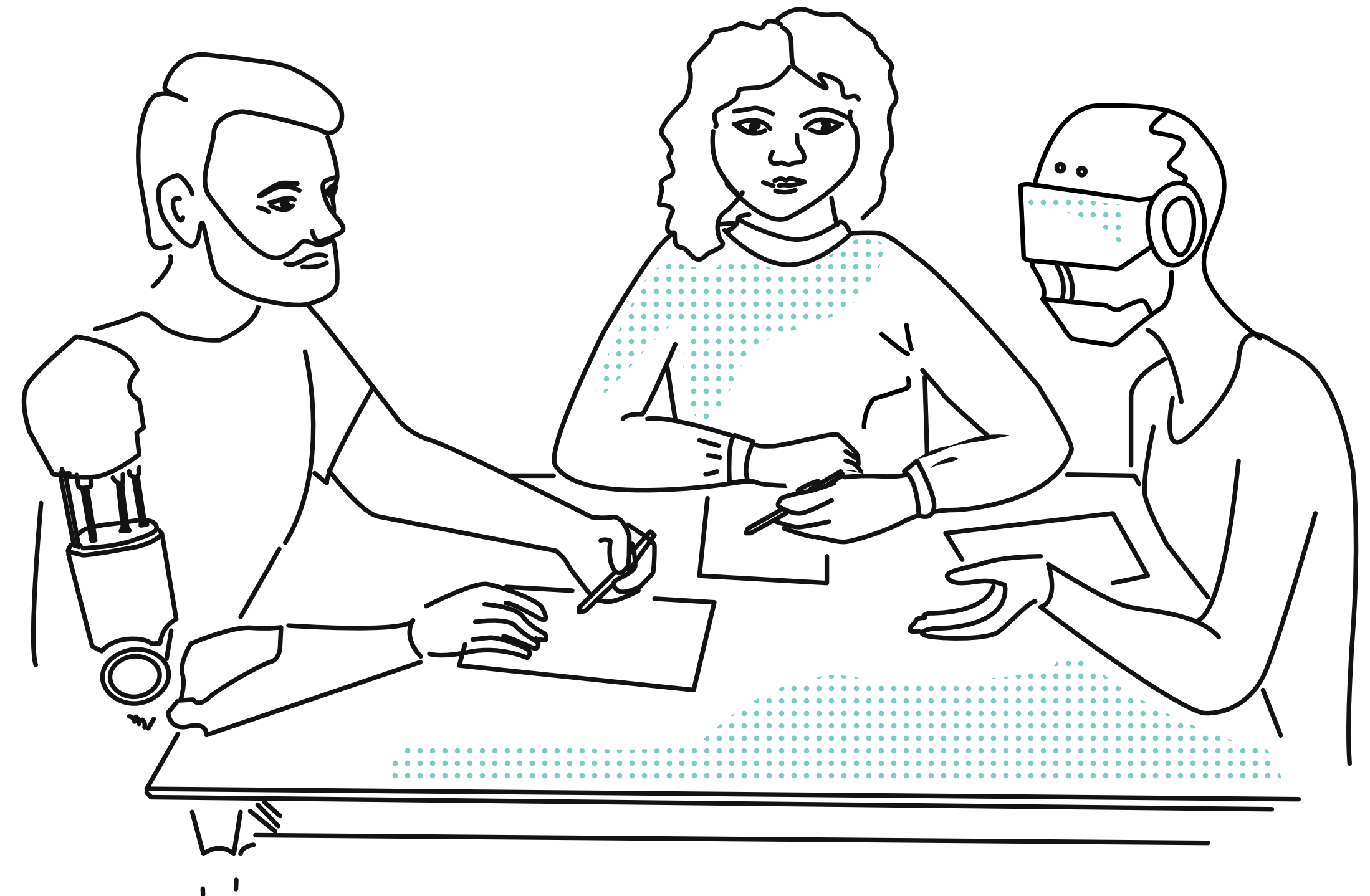
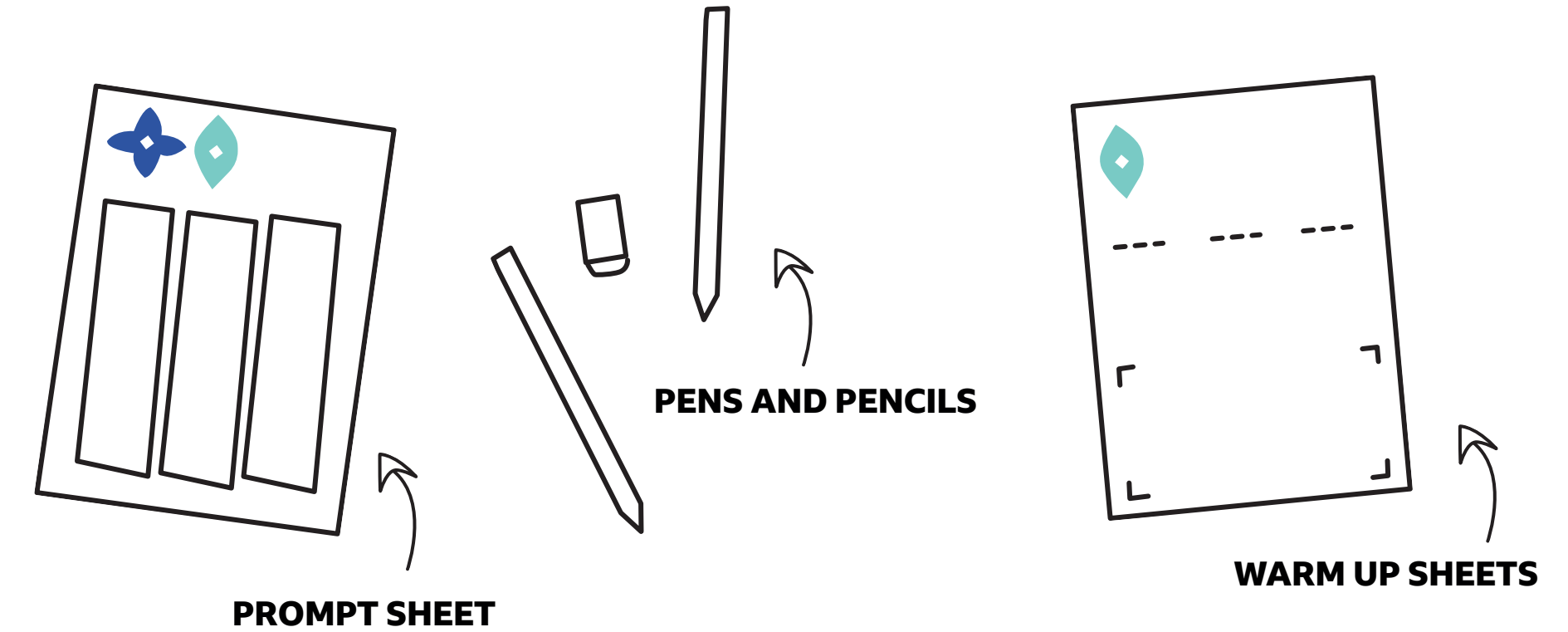



# STEP 2 EXPLORE

## Objective

Give depth to your team's particular future world by expanding on its implications

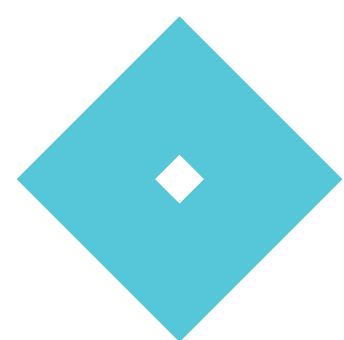

# STEP 2 EXPLORE

- Take an Explore Sheet, which you will fill in as a team.
- Reflect on your designated Future, looking a few decades ahead at least. If this type of future were to come about, what kind of society, technology, economy, environment and politics might we see?
- Take turns adding sentences under each heading, in any order. Later answers can build on earlier ones, so you're gradually painting a fuller picture of how this future world looks!
- Be as audacious and creative as you wish – while making sure that what you describe aligns clearly with the kind of Future you've been invited to explore.

## MATERIALS

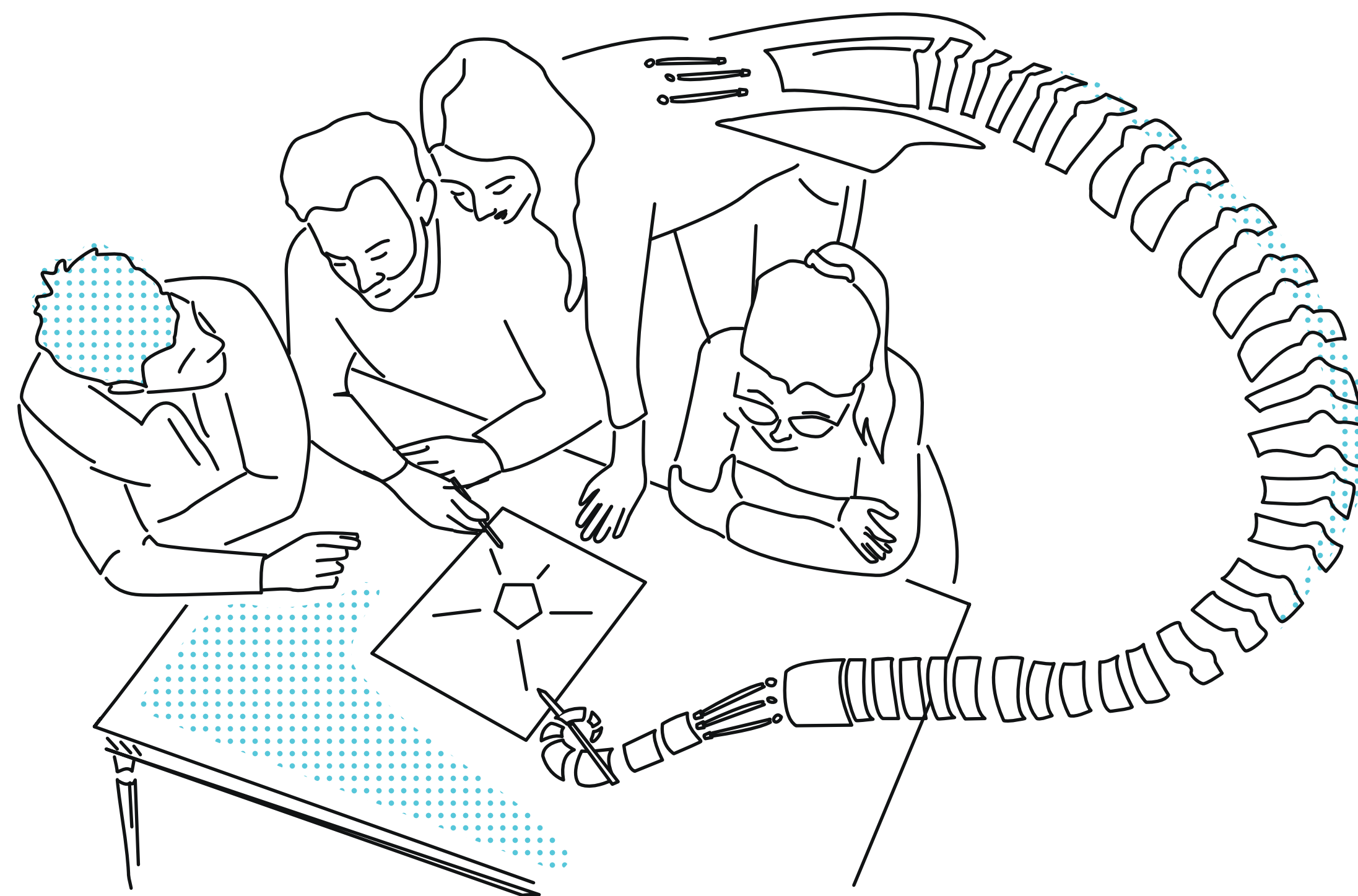
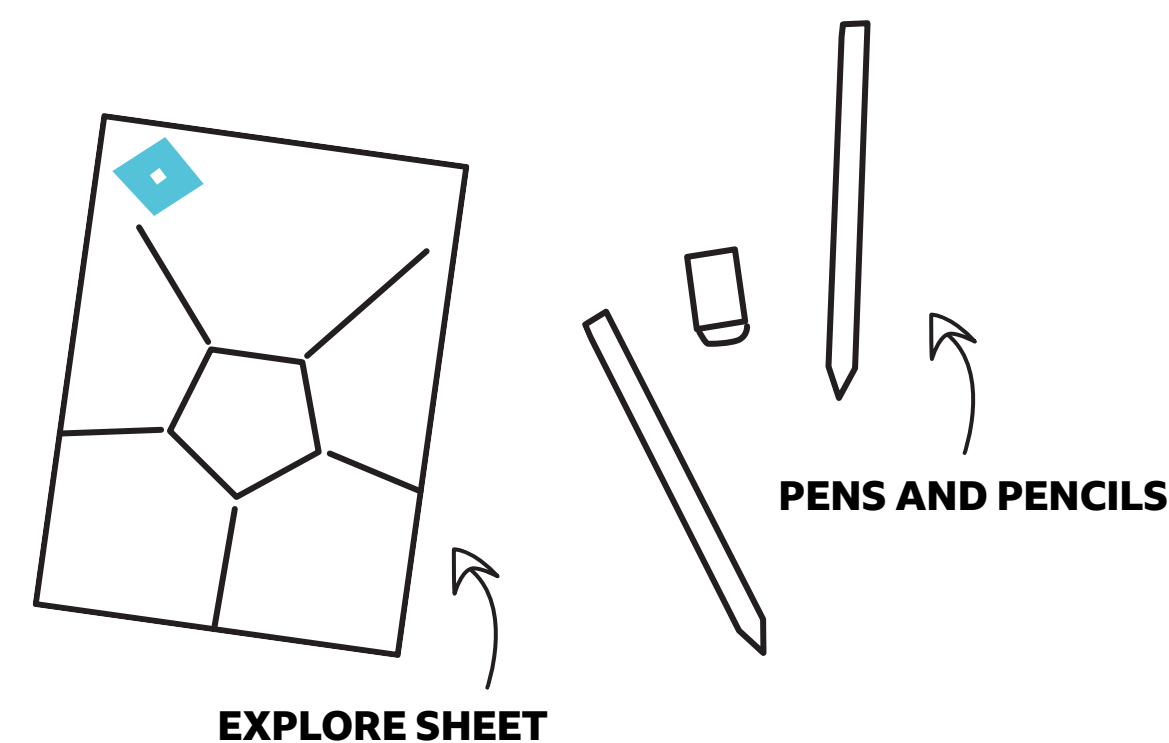



# STEP 3 GATHER

## Objective

Retrieve the materials with which to  
make artefacts for your stall



# STEP 3 GATHER

- In a moment, one person from each team will go and source one item from the Future Fodder pile. This is the stuff you'll use to create future artefacts for your Bazaar stall!
- Move briskly but safely – walk, don't run – and don't take too long, so that you get back to your table quickly and the next person can go.
- Don't overthink it, but bear the previous step in mind when making your selections – are there any Future Fodder items that evoke a feeling of your particular future?
- Repeat the process until each team has enough items to work with.

## MATERIALS

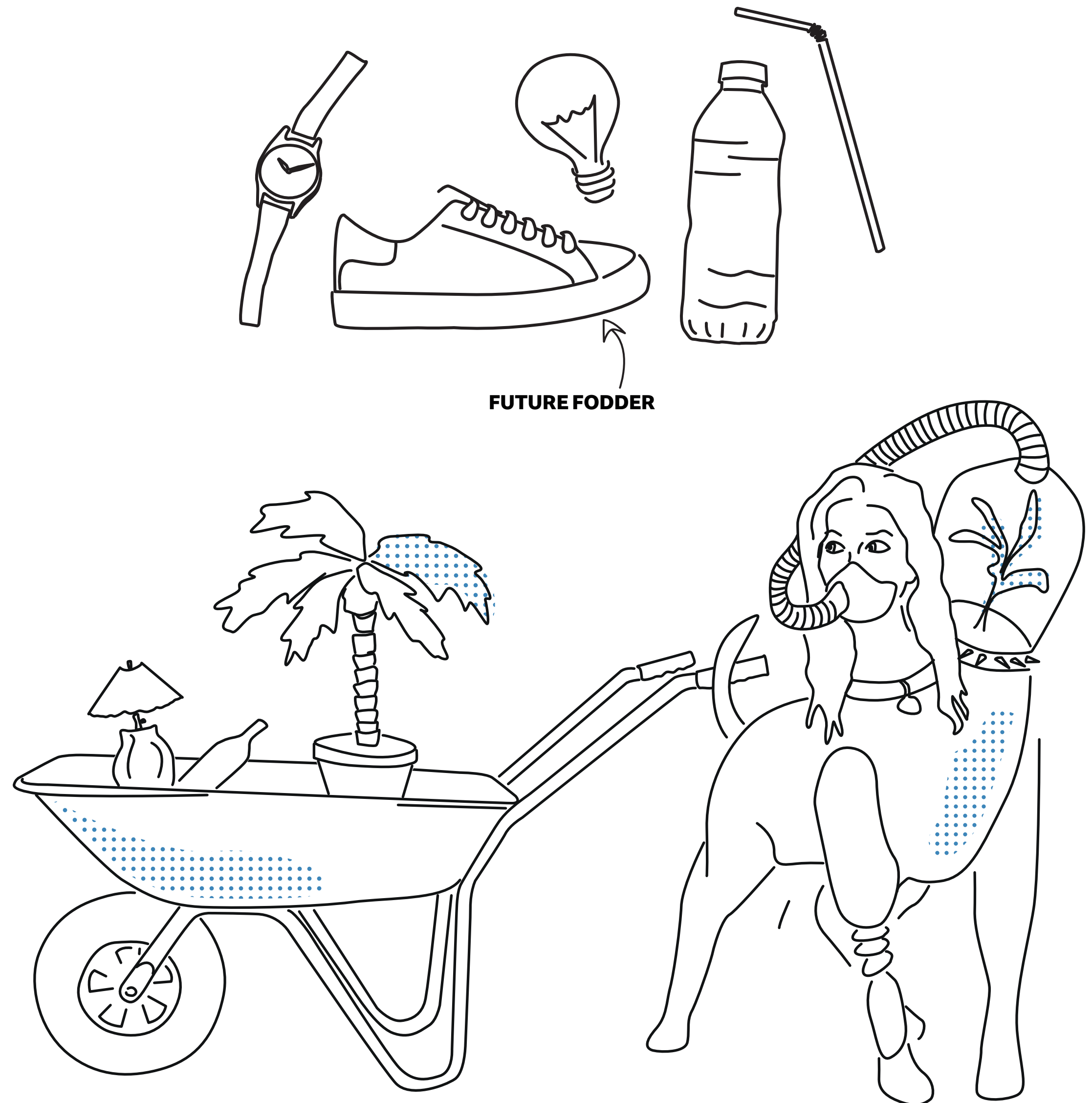



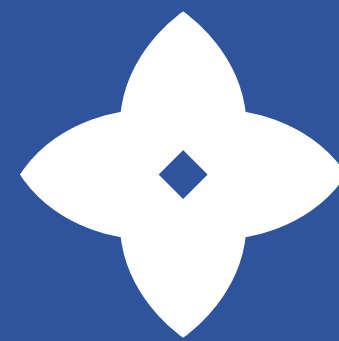

# STEP 4 IDEATE

## Objective

Generate future artefact ideas

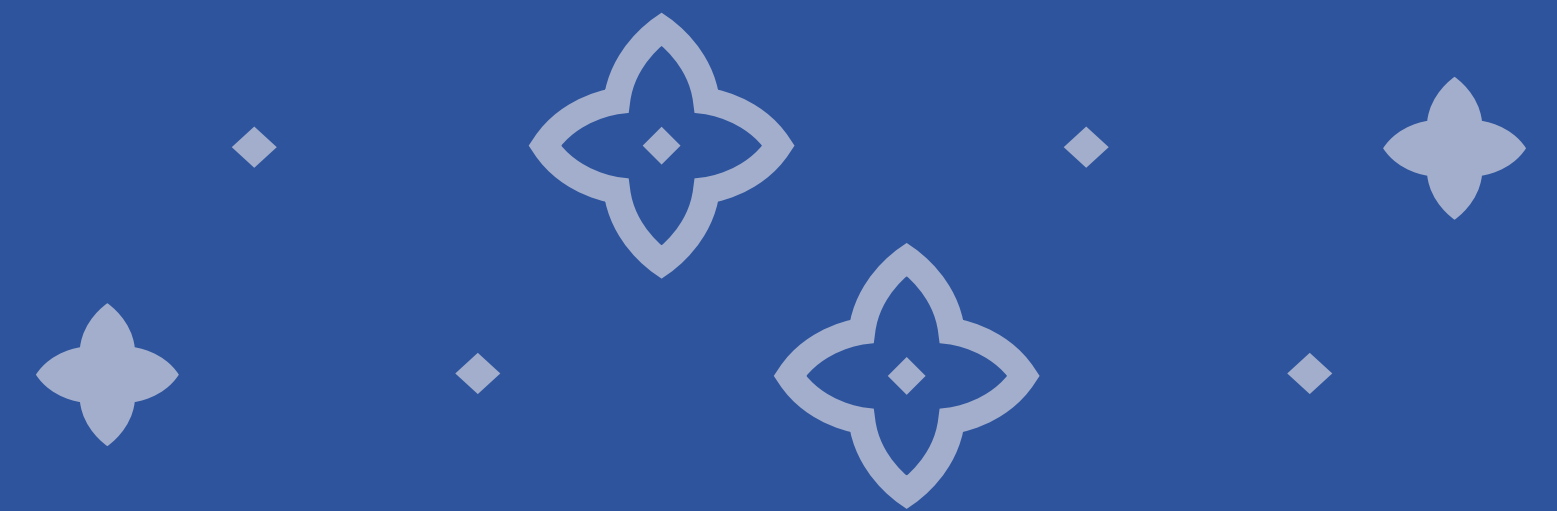



# STEP 4 IDEATE

- As in the Warm Up stage, you will now use unique combinations of Futures, Things and Themes to generate future artefact ideas. But this time, you'll use physical Future Fodder items as part of each prompt.
- Put the (completed) Explore and (blank) Ideate Sheets together to create a prompt. Place one future fodder item at a time in the centre of the prompt.
- Try cycling through different Themes drawn from the Prompt Sheet and ask: how might you reimagine and remake this physical item as a distinctive artefact from your particular future?
- Brainstorm as many ideas as you can for each item.
- Consider the potential for hacking and combining objects too!

## MATERIALS

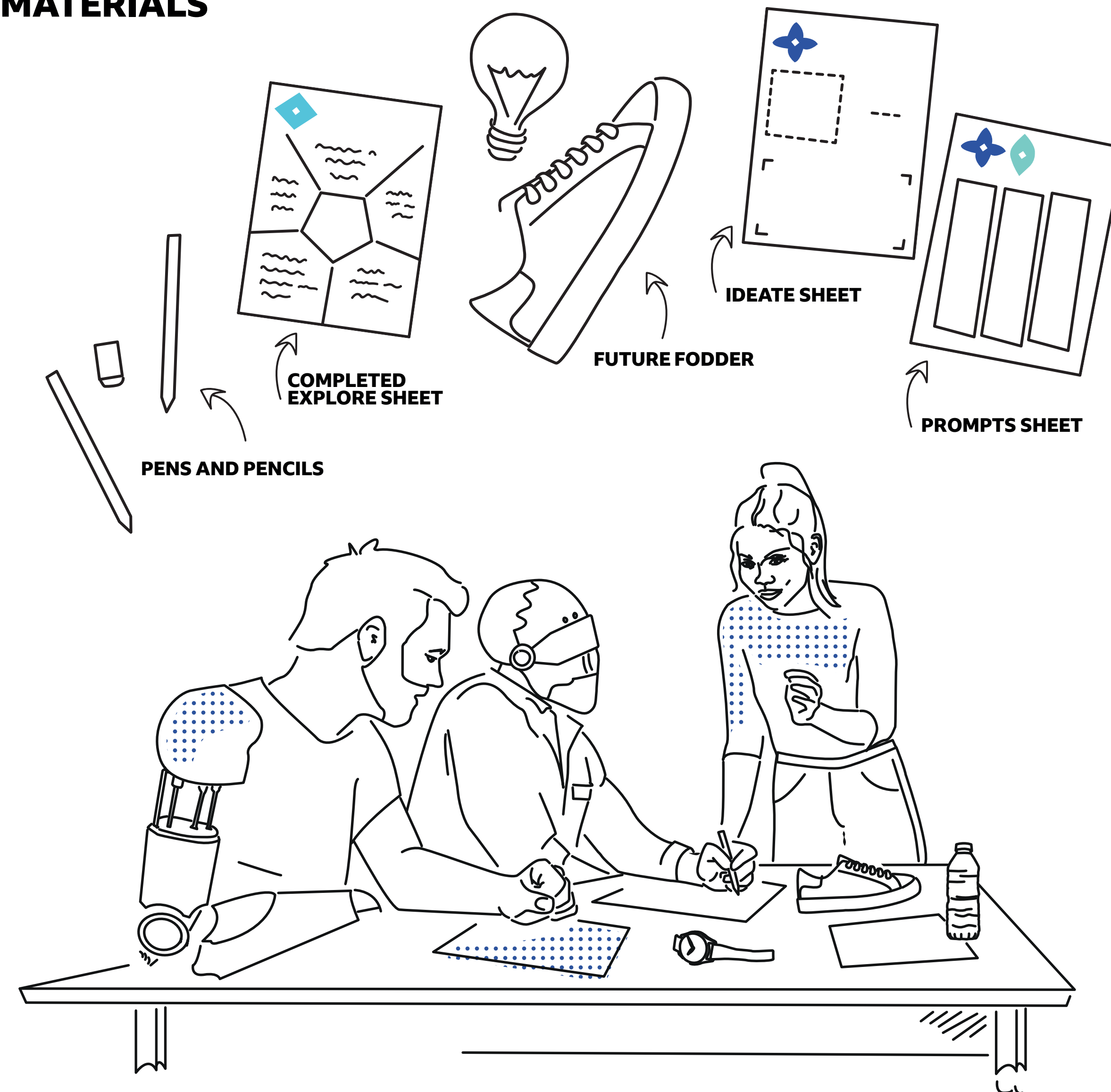

**BREAK**

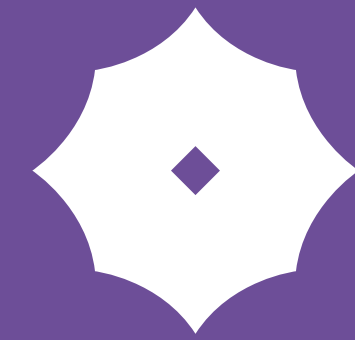

# STEP 5 CREATE

## Objective

Make and label future artefacts for sale

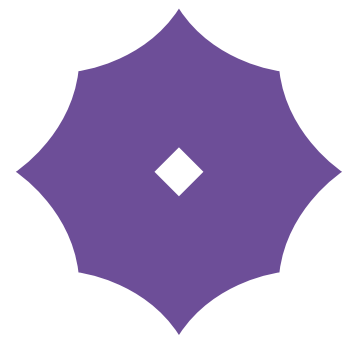

# STEP 5 CREATE

- Channel your creativity! As a team, pick your best ideas. Consider how the candidate artefacts would, both individually and as a set, evoke your designated future.
- Now you can start making future artefacts. Collaborate, or work in parallel; it's your choice. But by the end of this step you should have produced at least 1–2 artefacts per person.
- Use Future Fodder, glue, paper, scissors (etc) to create, alter, mutate and merge items. Or, keep them close to the way they came, and transform their meaning by using the Artefact Tags.
- A final future artefact should let a visitor grasp the story behind it, and how it evokes your future. Remember that each artefact needs its own Tag written from within the perspective of the future where it is for sale.

## MATERIALS



FUTURE FODDER



CONSTRUCTION  
MATERIAL & TOOLS

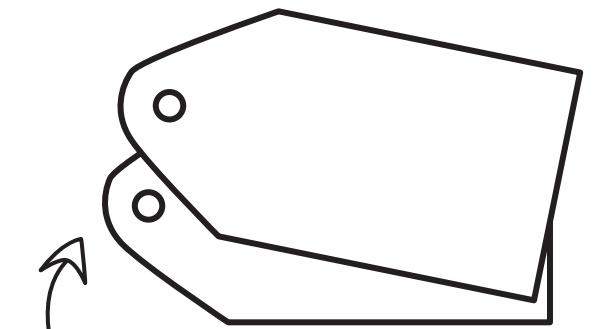

ARTEFACT TAGS



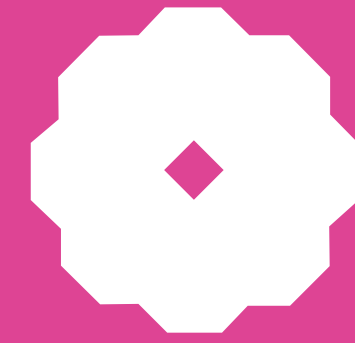

# STEP 6 SET UP

## Objective

Build your teams stall

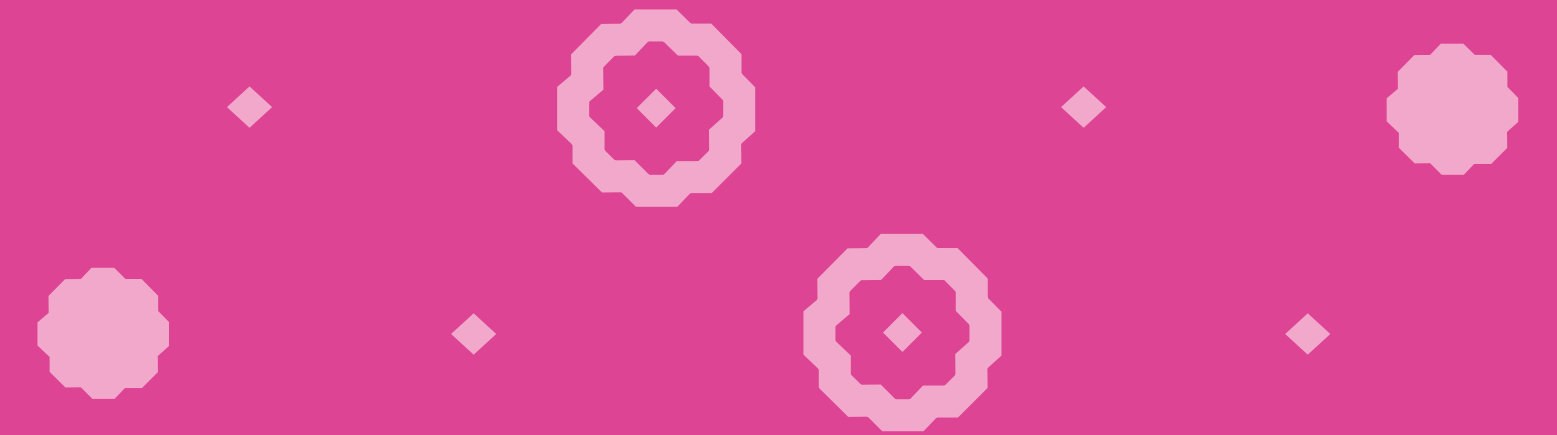
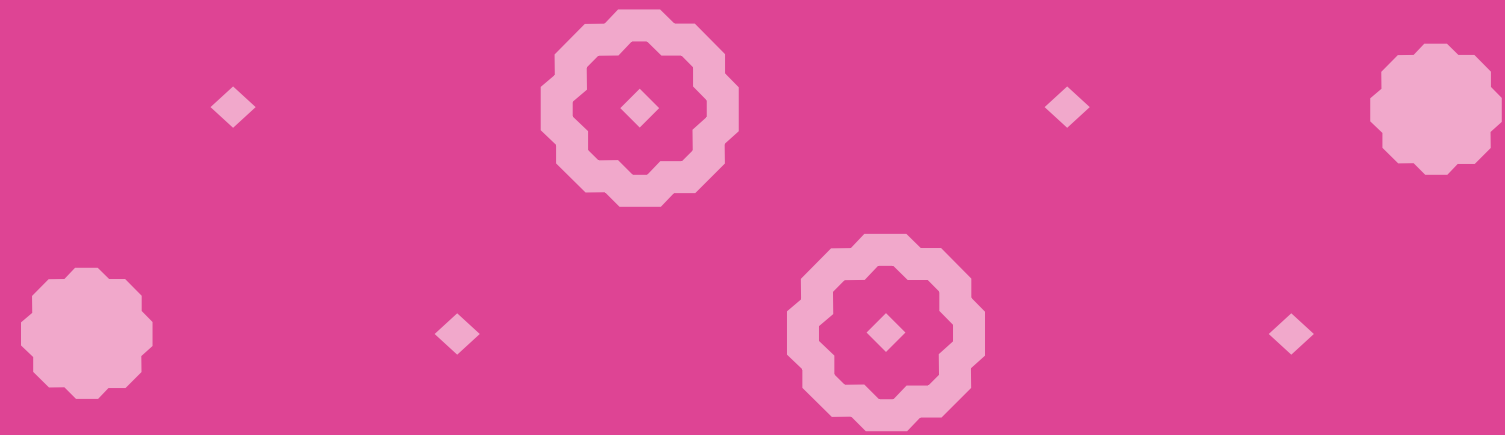

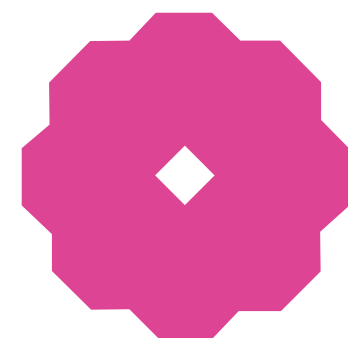

# STEP 6 SET UP

- To start, create a Stall Banner as a centrepiece for your display. The branding should clearly describe and “sell” your type of Future and its special merchandise. What is your collection of artefacts about? Use short, attention-grabbing text.
- Put extra material and your imagination to work in decorating the stall. Remember – this is an interdimensional multi-futures marketplace, so let your creativity run wild!
- A Bazaar is nothing without its merchants and customers, and you’ll alternate between these roles next, so gear up to be in character. What lines might you say to attract customers? Are there any materials you could use to craft costumes?

## MATERIALS



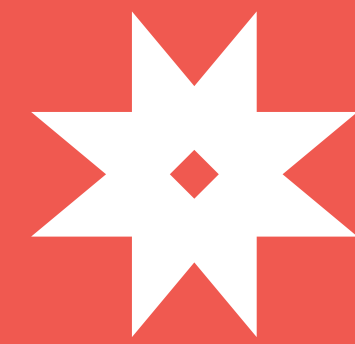

# STEP 7 RUN

## Objective

Experience your creative collection

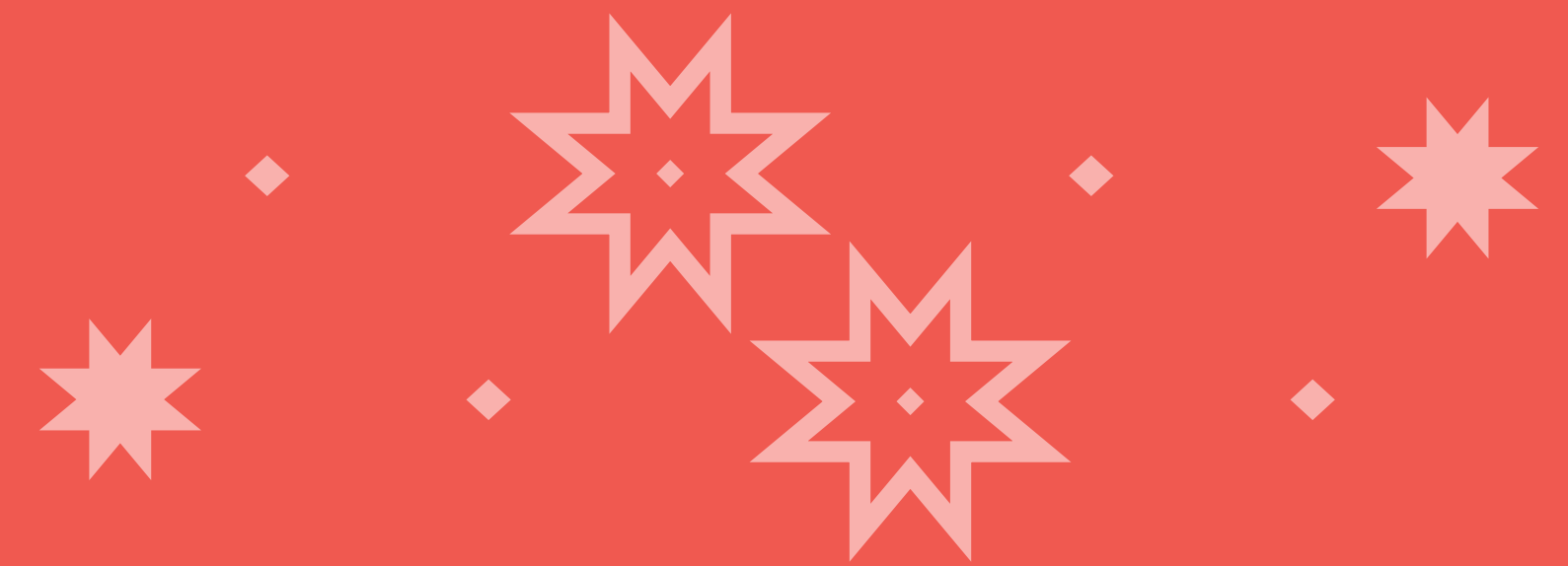
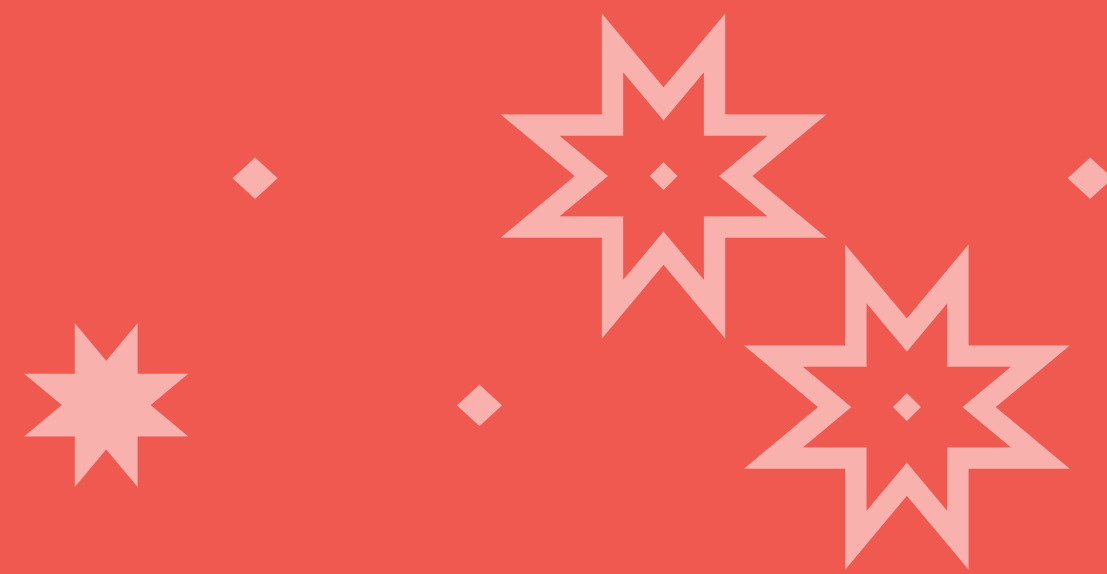



# STEP 7 RUN

- When the Bazaar officially opens, at least one team member will be a “merchant” staffing the stall (two is best) while other team members roam as customers, currency in hand. Decide who’s doing what first. You’ll be asked to swap roles halfway, but make sure everyone gets a chance to play both sides.
- Merchants: Stay in character at all times and make every effort to “sell” your artefacts!
- Customers: Keep an eye out for artefacts that excite you, scare you, or make you laugh. Leave your currency by the most fun and thought-provoking artefact you can find, so that everyone can see which pieces tell the most compelling stories.
- Take pictures and videos to post on social media and share with the wider community using the #FuturesBazaar hashtag!

## MATERIALS

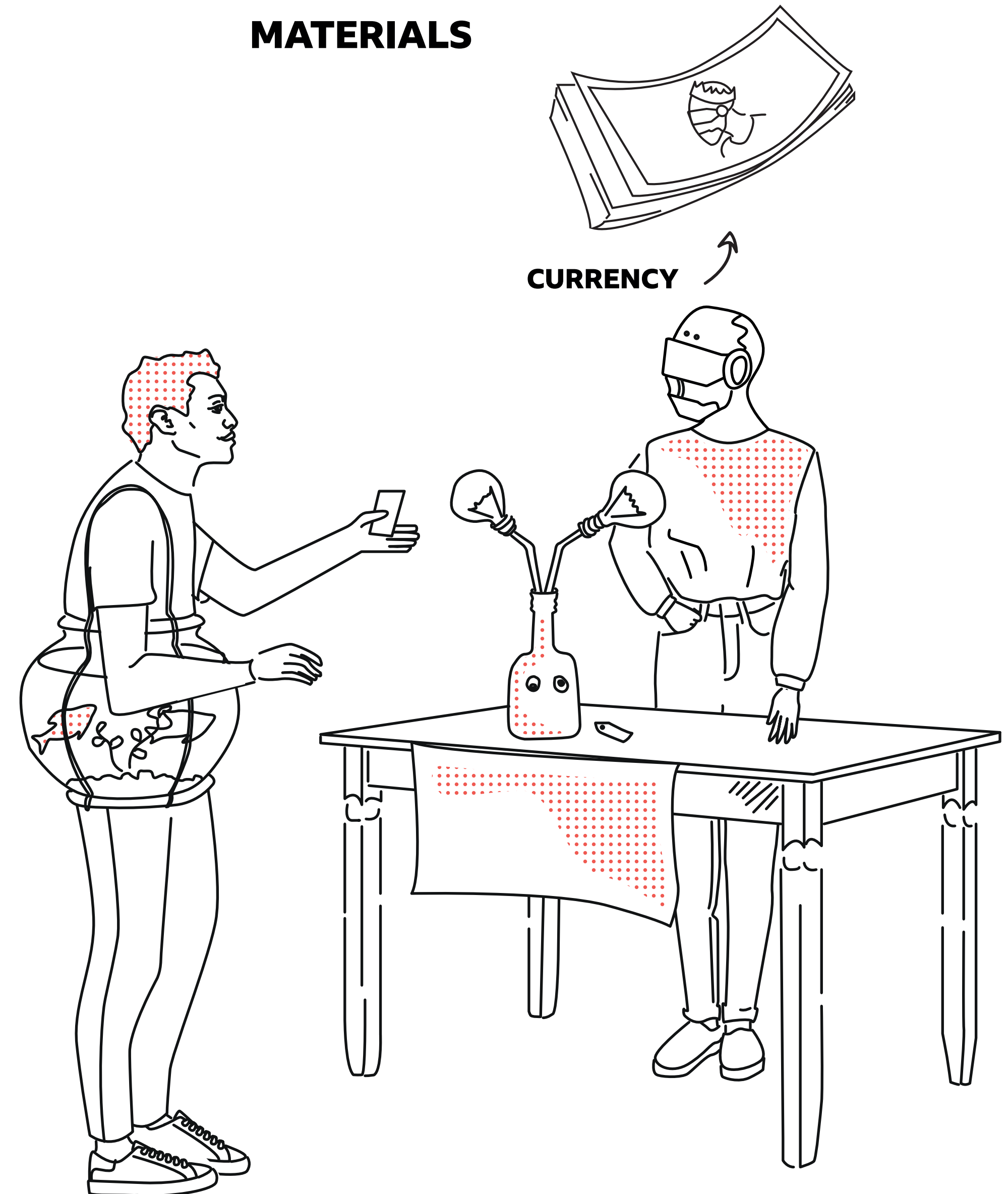

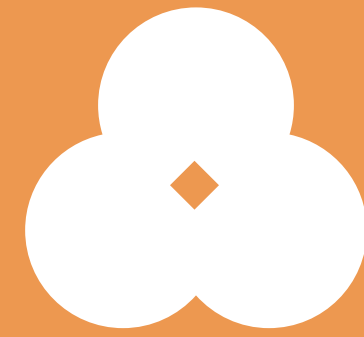

# STEP 8 TAKE DOWN

## Objective

Leave the space the way you found it

# STEP 8 TAKE DOWN

- Right – we're done!
- Double check that stalls and artefacts have been well documented before clearing them away.
- If anyone wants to keep any of the artefacts for posterity, please feel free.
- Everything else should be cleaned up. Make sure to recycle all recyclable materials!

## MATERIALS

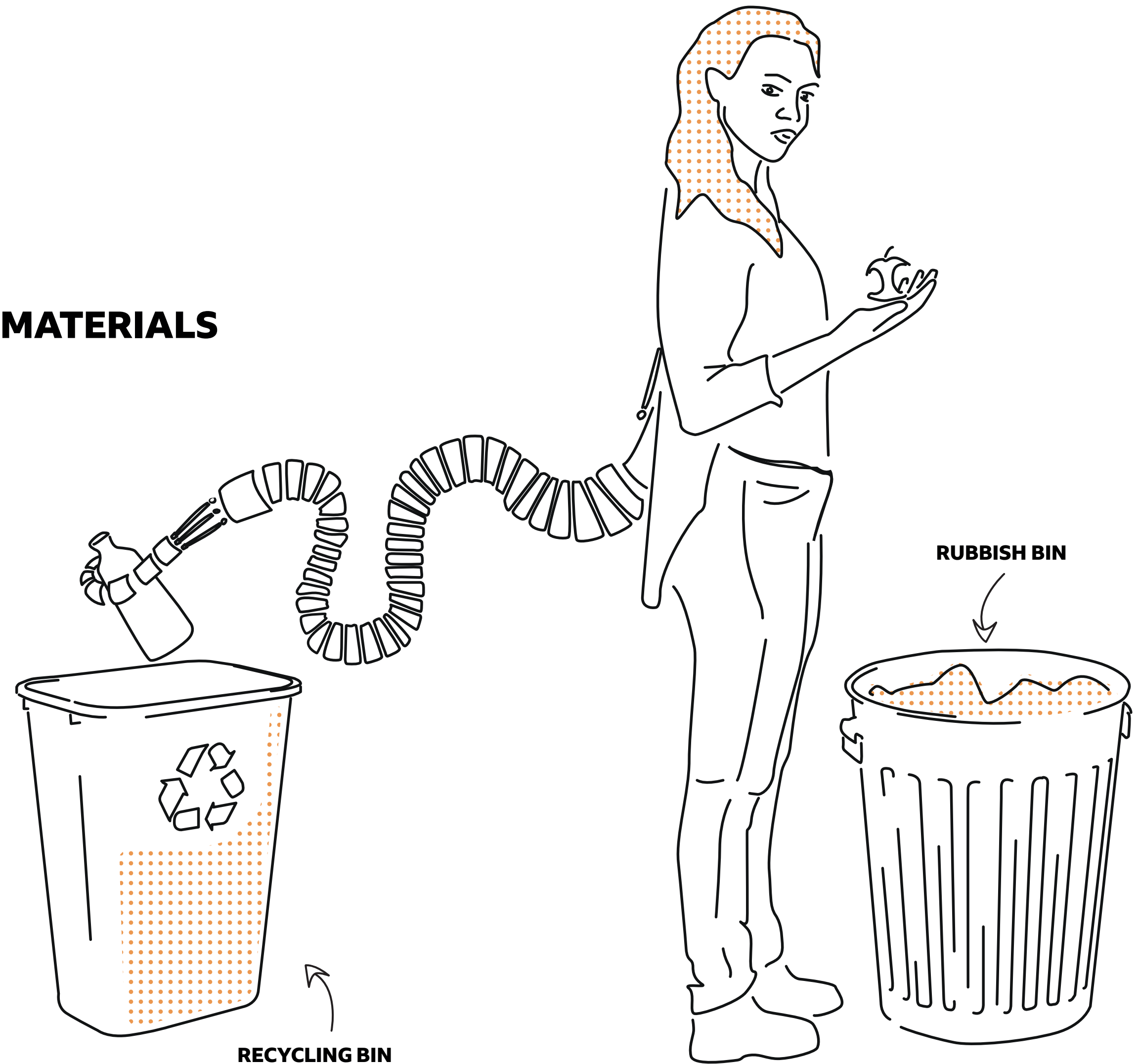



# THANK YOU

To learn more about this event  
and download the toolkit to run your own, visit  
[bbc.co.uk/gel/features/futures-bazaar-toolkit](https://bbc.co.uk/gel/features/futures-bazaar-toolkit)





... **2** ...  ... **2** ...  
#FuturesBazaar #FuturesBazaar

... **2** ...  ... **2** ...  
#FuturesBazaar #FuturesBazaar

... **2** ...  ... **2** ...  
#FuturesBazaar #FuturesBazaar

... **2** ...  ... **2** ...  
#FuturesBazaar #FuturesBazaar

... **5** ...  ... **5** ...  
#FuturesBazaar #FuturesBazaar

... **5** ...  ... **5** ...  
#FuturesBazaar #FuturesBazaar

... **5** ...  ... **5** ...  
#FuturesBazaar #FuturesBazaar

... **5** ...  ... **5** ...  
#FuturesBazaar #FuturesBazaar

... **10** ...  ... **10** ...  
#FuturesBazaar #FuturesBazaar

... **10** ...  ... **10** ...  
#FuturesBazaar #FuturesBazaar

... **10** ...  ... **10** ...  
#FuturesBazaar #FuturesBazaar

... **10** ...  ... **10** ...  
#FuturesBazaar #FuturesBazaar



NEEDED FOR STEP 2

# EXPLORE SHEET

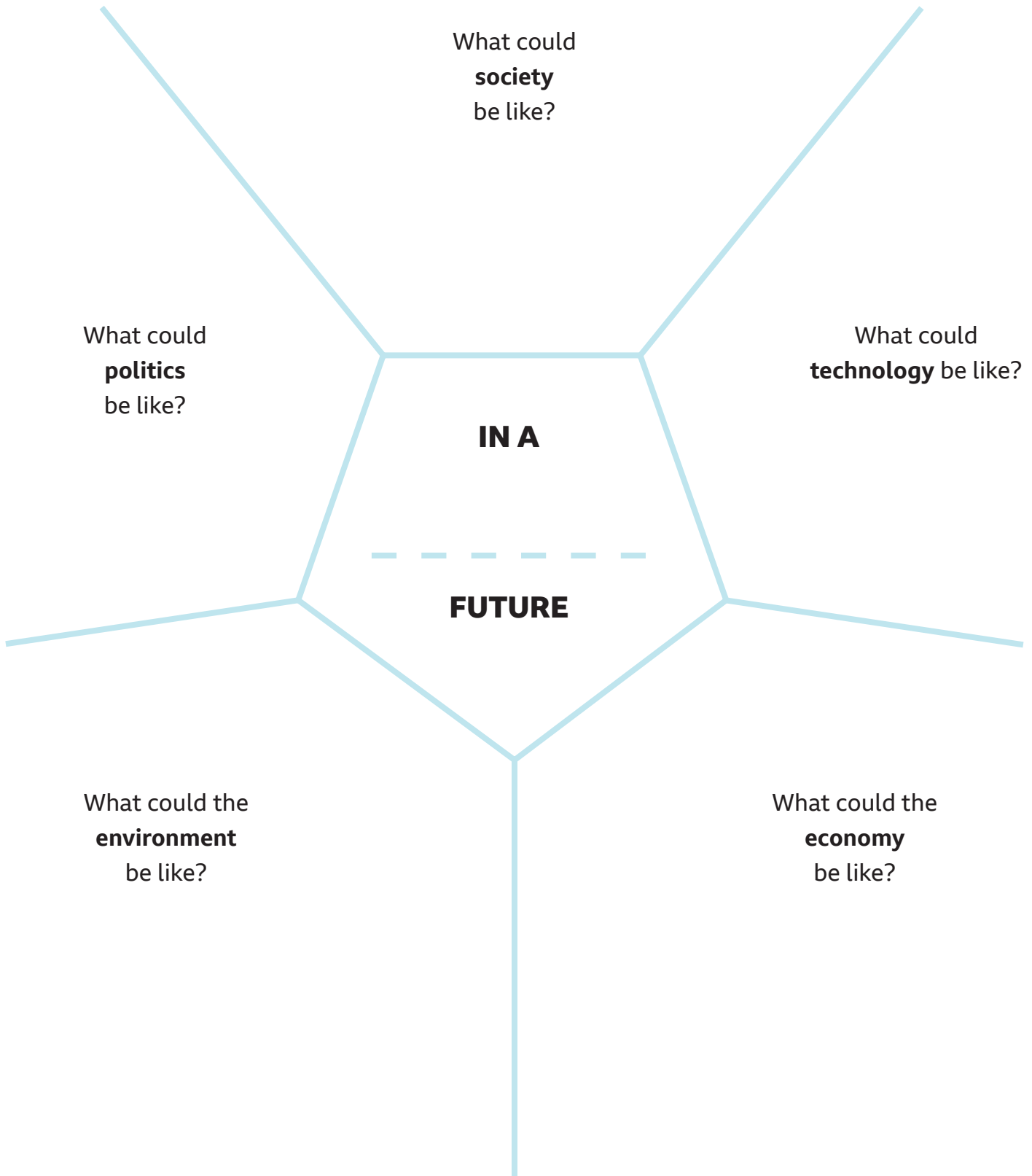
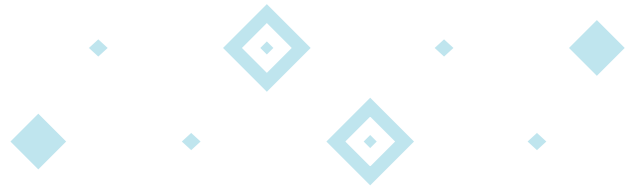



NEEDED FOR STEP 4

# IDEATE SHEET

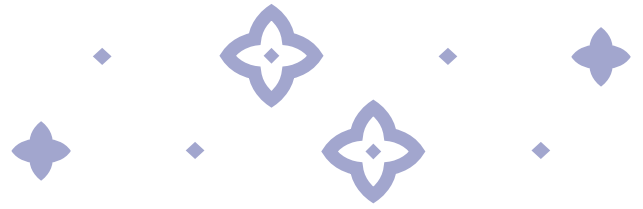

Place Future Fodder item(s) here

**THERE IS A...**

Enter Theme from Prompt Sheet

**RELATED TO...**

-----

***What is it?***

Describe or sketch this thing from the future





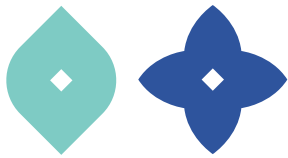

NEEDED FOR STEPS 1 & 4

# PROMPT SHEET

Choose from these prompt elements for the Warm Up and Ideate exercises

## FUTURE

Needed for Step 1



BEAUTIFUL  
BIZARRE  
BRIGHT  
CREATIVE  
DECOLONISED  
DEPRESSING  
FAIR  
FAST  
FEMINIST  
FREE  
GLOBAL  
GRASSROOTS  
GREEN  
HIGH-TECH  
HILARIOUS  
INNOVATIVE  
JOYFUL  
MUNDANE  
NOIR  
PLAYFUL  
QUEER  
REACTIONARY  
RECOVERING  
REGIMENTED  
RESILIENT  
SAD  
SCARY  
SELFISH  
SMART  
STERILE  
THRILLING  
VOLATILE  
WILD  
WISE

## THING

Needed for Step 1



APP  
BESTSELLER  
BREAKTHROUGH  
BUILDING  
DEVICE  
DISASTER  
DRUG  
FESTIVAL  
FLAG  
FOOD  
GAME  
GARMENT  
HEADLINE  
HEIRLOOM  
INVENTION  
JOB  
KIT  
LAW  
MACHINE  
MAP  
MASK  
MONUMENT  
NEWS REPORT  
ORGANIZATION  
PLAYTHING  
POSTER  
PRODUCT  
PUBLIC SERVICE ANNOUNCEMENT  
RITUAL  
SONG  
TATTOO  
TOOL  
VIDEO  
WEAPON

## THEME

Needed for Steps 1 & 4



ANIMALS  
ARTIFICIAL INTELLIGENCE  
CITIES  
CLASS  
CLIMATE CHANGE  
DEATH  
THE ECONOMY  
EDUCATION  
ENERGY  
THE ENVIRONMENT  
FAMILY  
FARMING  
GENETICS  
GOVERNANCE  
HEALTH  
IDENTITY  
IMAGINATION  
JUSTICE  
LEISURE  
LOVE  
MEMORY  
MONEY  
THE OCEAN  
RELIGION  
RESOURCES  
SCIENCE  
SPACE  
SPIRITUALITY  
STORYTELLING  
SURVEILLANCE  
TRANSPORTATION  
WAR  
WATER  
WORK



NEEDED FOR STEP 1

# WARM UP SHEET



Enter **FUTURE**, **THING** and **THEME** selections from the Prompt Sheet

**IN A**

**THERE IS A**

**RELATED TO**

-----

-----

-----

**FUTURE**

*What is it?*

Describe or sketch this thing from the future

