



HI

C L I M B E R

TELESCOPIC

Excavator



HI

C L I M B E R

TELESCOPIC

Excavator

High



Remote



Far-off



Under



DESIGN CYCLE

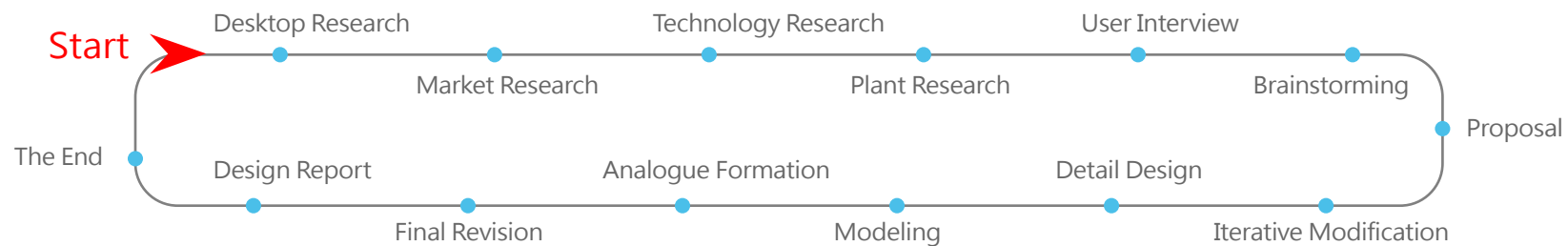

RESEARCH STUDIES



IDEATION



Some Concepts Selected for Evaluation
Picking up the best ones!

We are continually in progress. Today, excavators can no longer meet the current needs of the excavator working. Workers are now seeking for more efficient, more mobile, farther digging, safer, and better user experience excavator. The challenge is how to find and breakthrough innovative and design bottleneck in this already very mature industry and how to design a really need mechanical products to user.

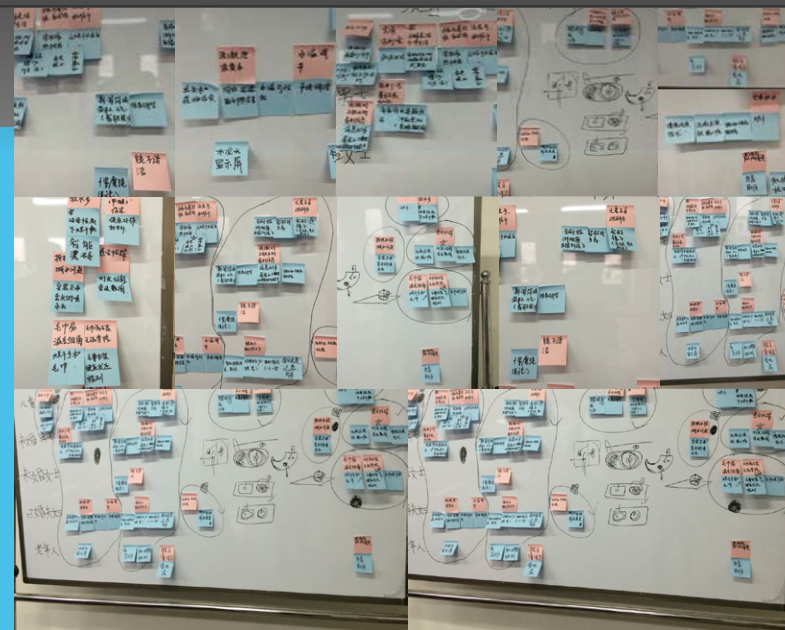

RESEARCH STUDIES



MODELING



Structuring the Research Results

Plant research

Design is a rigorous process. We adopted the desktop research - Market Research - Technical Study - Plant Research -User Interviews - Several Rounds of brainstorming - Creative Proposal - Design Modify - Further Design - Modeling - Modeling Modify -- Design Test - Final Modify - Design report - End of the Project, which is the entire design process. For example, when in the research on structure, we analyze the folding mechanism of items, explore the best structure. We also have interviewed with the workers, technicians, designers and so on, and conducted experiments and tests for counterweight. We also have technology research for 3D simulation of ground conditions, such as "Renault virtual reality technology center."



PRODUCT DEVELOPMENT

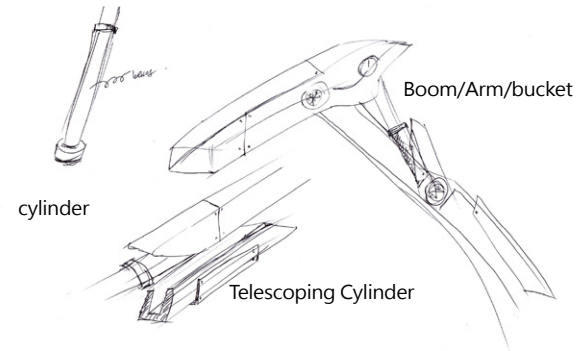
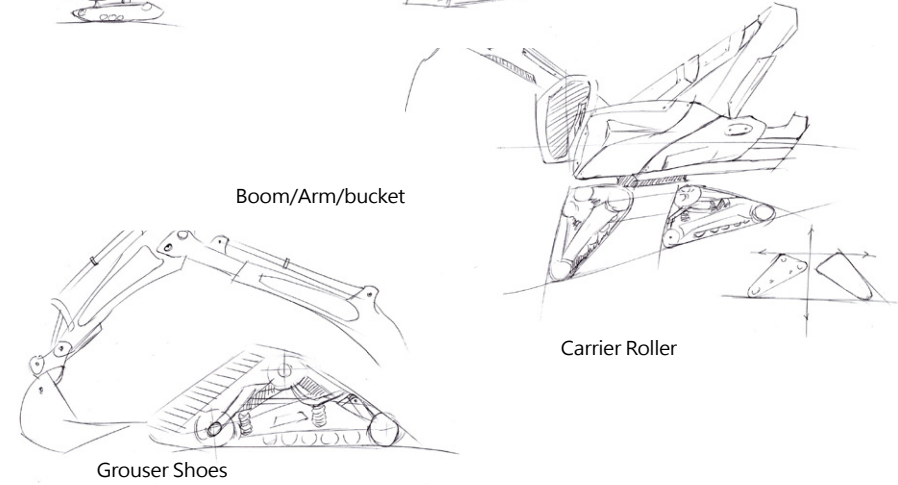
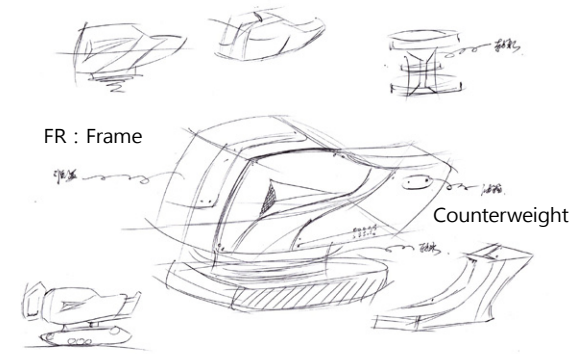
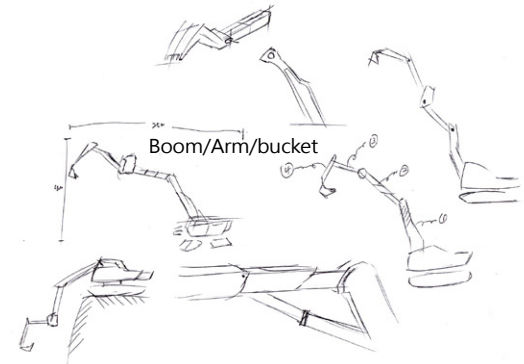
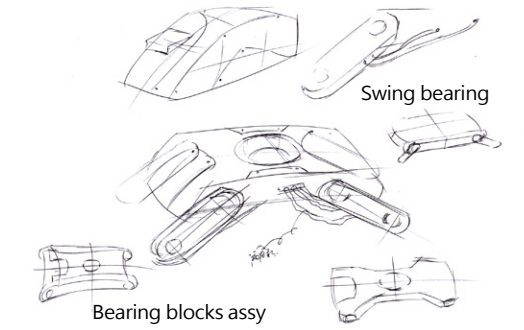
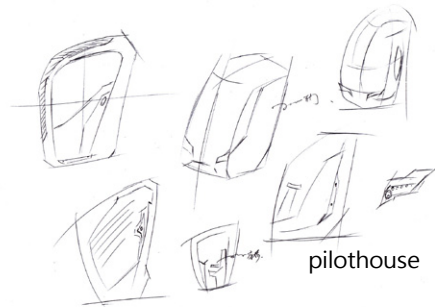
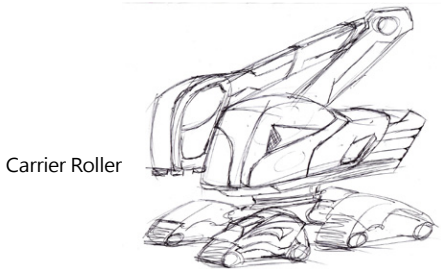
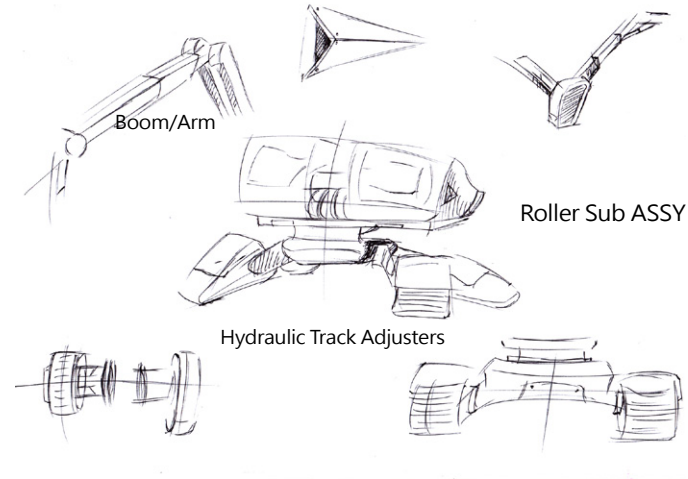

3D Model Making

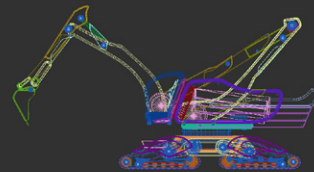
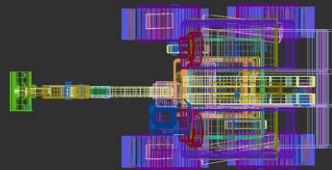
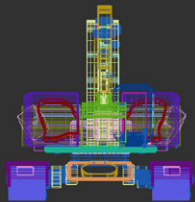
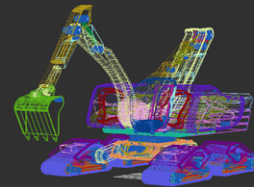
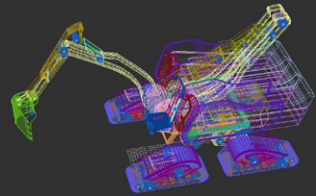
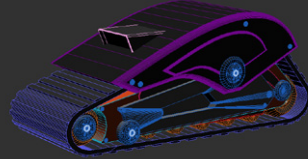
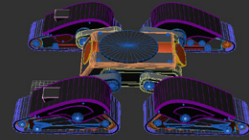
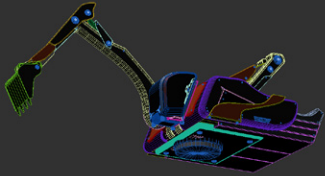
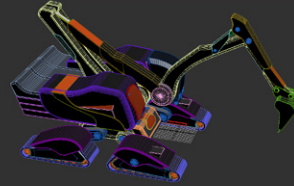
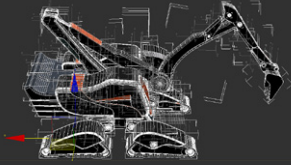

Front

Top

left



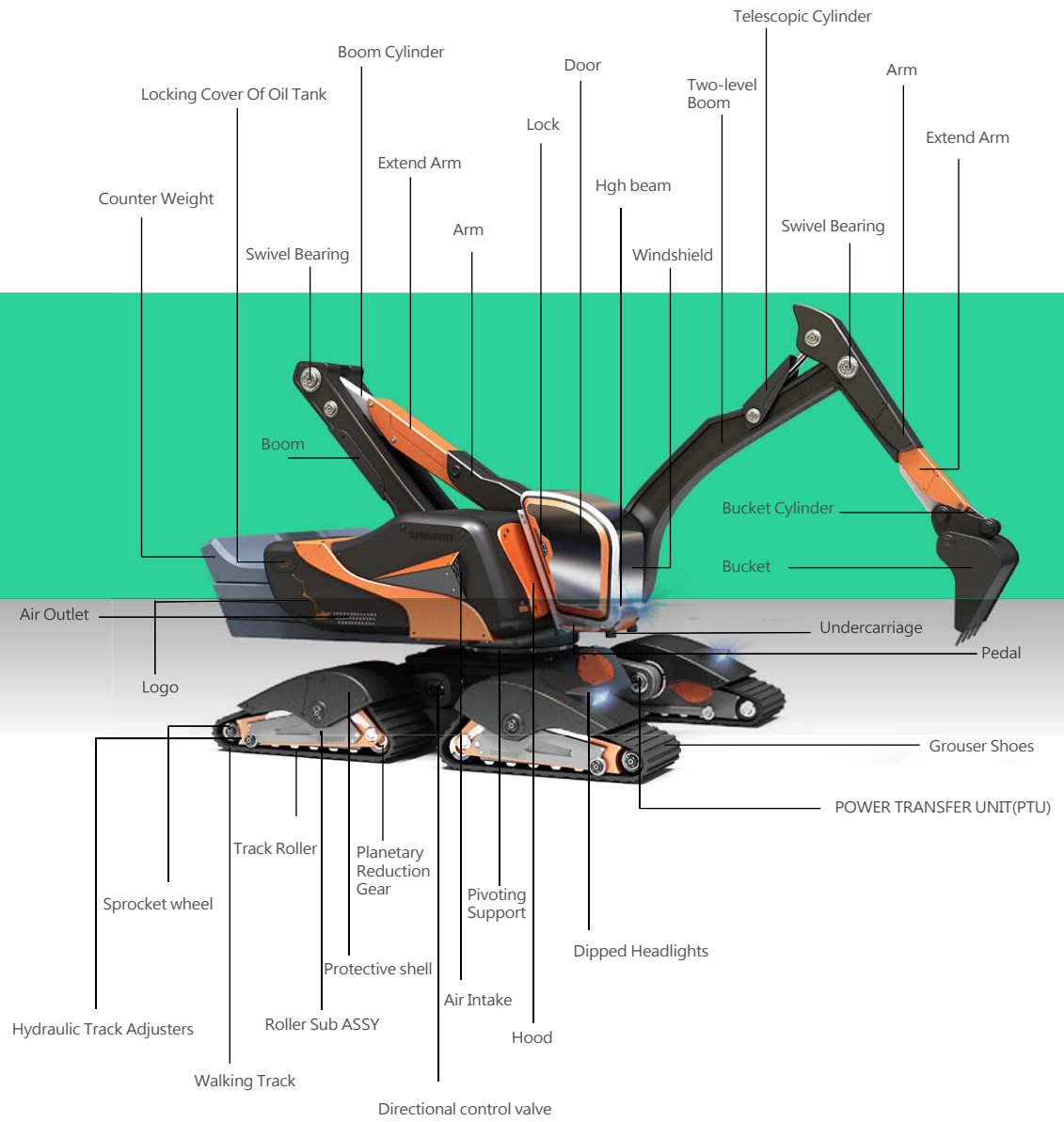



Hydraulic hydraulic arm is hidden in a case to protect the Hydraulic rod from being damaged.



Secondary growth pole, when the arm is not long enough, will grow to increase the digging distance.



Level jib. Double jibs can increase the endurance to make sure the normal operation of the jibs and arms.



Bob-weight . You can change the body weight in order to adapt to the various digging stances by moving the bob-weight backward or forward.



The wheels of Four-wheel drive crawler will be automatically adjusted to an appropriate position to ensure the body are kept balanced, stable and secure. The wheels turn to four different directions in order to keep stable to avoid slipping.

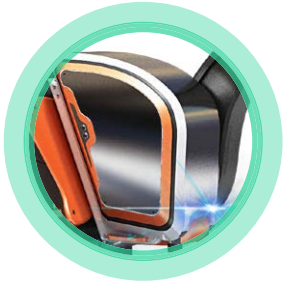

The panoramic sunroof and cab door ensure that there is no fade zone.



Two types of door locks: Password lock and emergency lock.



Air intake is used for cooling the engine.



Dipped headlights in the apron wheels can light the surrounding environment to avoid the accident caused by the insufficient light.



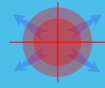

Four-driven-wheel has crawler belts. The wheels will adjust themselves to suitable angle and status according to the ground conditions, aiming to ensure the balance, stability and safety.

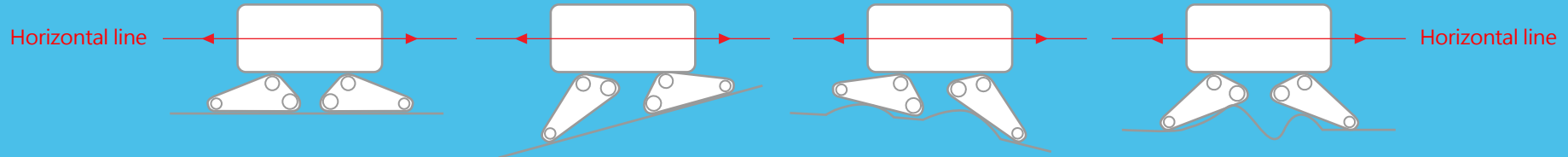

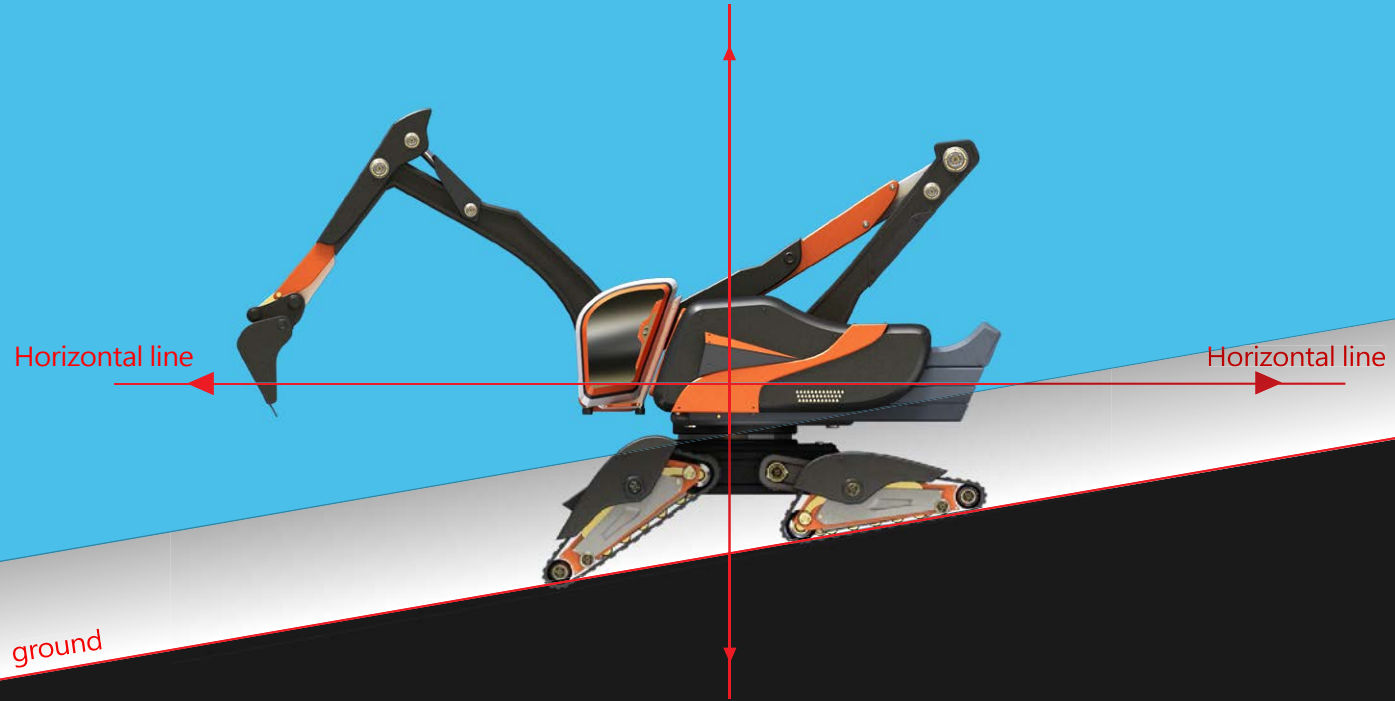
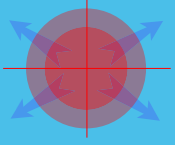

The wheels of Four-wheel drive crawler will be automatically adjusted to an appropriate position, to ensure the body are kept balanced, stable and secure.

The wheels turn to four different directions in order to keep stable to avoid slipping.



Inspired by the structure and working principle of the concrete pump truck.

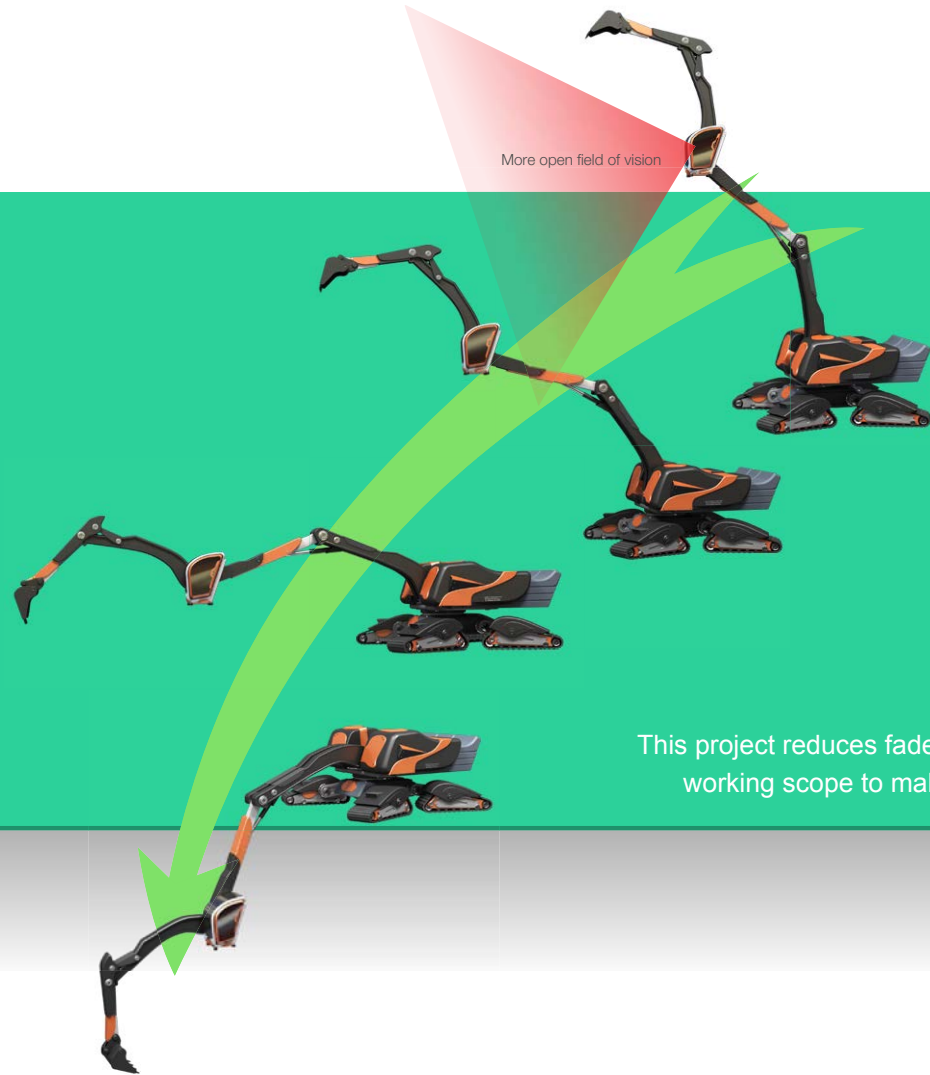

More open field of vision

This project reduces fade zone and widens the working scope to make it more flexible.

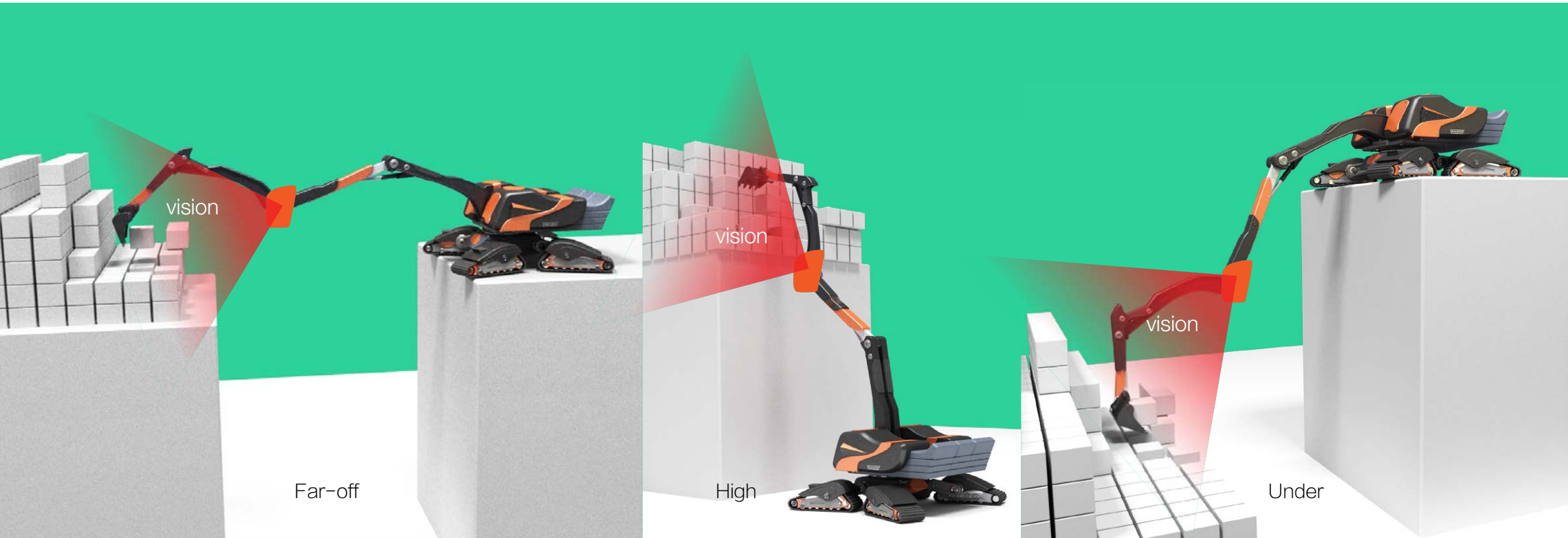

vision

Far-off

vision

High

vision

Under

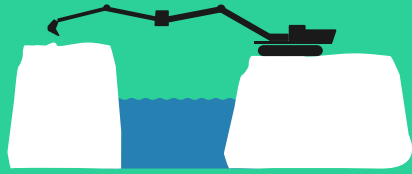

更远



更高



更深

The CLIMBER excavator is a latest model with four booms which is quite different from traditional excavator with only two. It helps a lot in promoting the height, depth and distance of its operation ability.

Since the traditional excavator has a fixed operation room, so it cannot avoid some blind spots during the operation, which may increase potential risks and danger. However, the reformative excavator solved this problem by equipping itself with a flexible and movable operation room. With this modified machine, the operator can control and adjust it to clean up the dead corner to ensure safety.

Drivers could achieve multi-forms of grabbing work by controlling the four booms to adapt to the complex environment around. This new grab excavator working field has been extended to as much as twice of traditional one because of its retractable folding structure design. It has excellent performance for grabbing work because it can cross rivers, stretch into cavities and reach for high level areas. Besides, the cab and the grabbing arm are designed into one-piece part, so that drivers could see the object much closer and clearer. In the meanwhile, the cab can still stay level to ensure excellent user experiences.



Inspired by the structure and working principle of the crane.

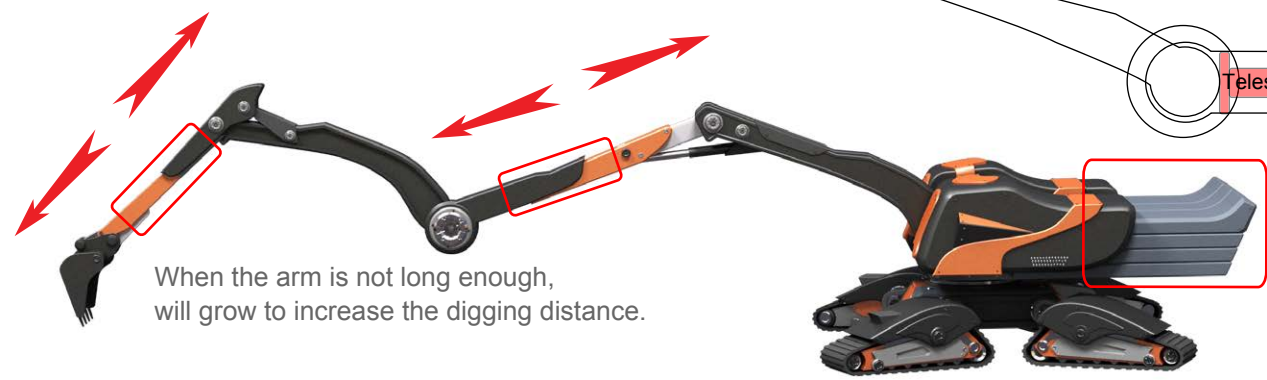

When the arm is not long enough, will grow to increase the digging distance.

- The retractable arm can expand the length regulation of mining excavation just like the crane, which has the hydraulic rods inside the boom to push the mining telescopic arm.
- The weight section in the excavators tail can change the centre of gravity by stretching the body to maintain the mechanical balance.

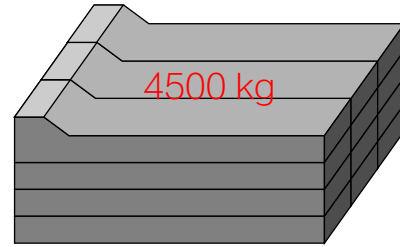

COUNTERWEIGHT

The bob-weights consist of 9 parts weighted 500kg, which can be increased or decreased according to the actual situation. The weight section also can change the centre of gravity by stretching the body to maintain the mechanical's balance.

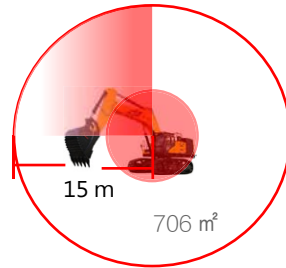

The mining range of ordinary excavator is 706 square meters, while the new one's is 1962.5 square meters.

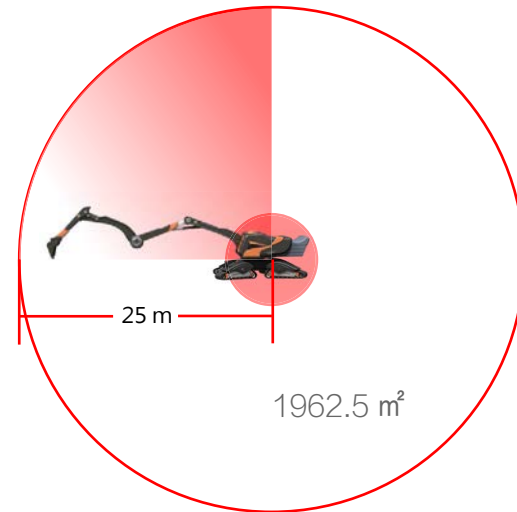

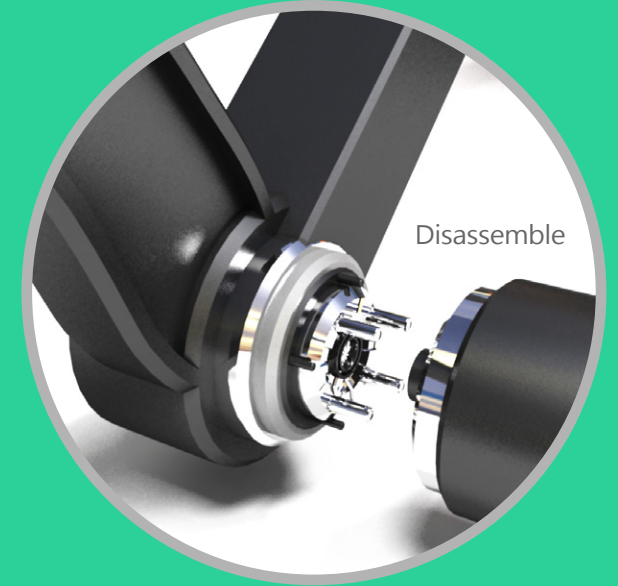
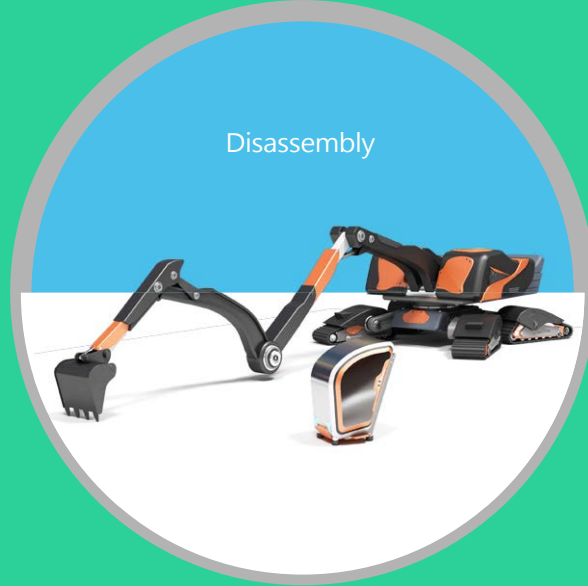

THE DETACHABLE CAB

In order to protect the driver from the dangers of construction scene. This removable driving zone is able to be removed and thus making it possible to achieve unmanned driving and remote control under severe working conditions.

REMOTE CONTROL

After removed, the driving zone can be placed in the safe zone to remote control, which adopt the newest technology such as 3D simulation, virtual reality, strengthened reality, risk analysis, GPS navigate, full-vision live broadcast and smart assisting operation.





3D SIMULATION ROAD CONDITIONS

3D simulation road conditions. It is a kind of new technology which is an interactive visual system to make people feel like being in the real scene. Applied to the excavator remote operation, this system is actually a kind of simulating technology, which can simulate the inner and outer conditions of excavator and achieve remote driving. The system projects 70 million pixels simulating images and owns the floating-point calculation ability of several, Thousands of billions times per second. This new system adopts digital database to simulate the whole car. This system can help future excavator achieve remote operation

Technology from <Renault Virtual Reality Technology Center>



CLIMBER

TELESCOPIC

Excavator





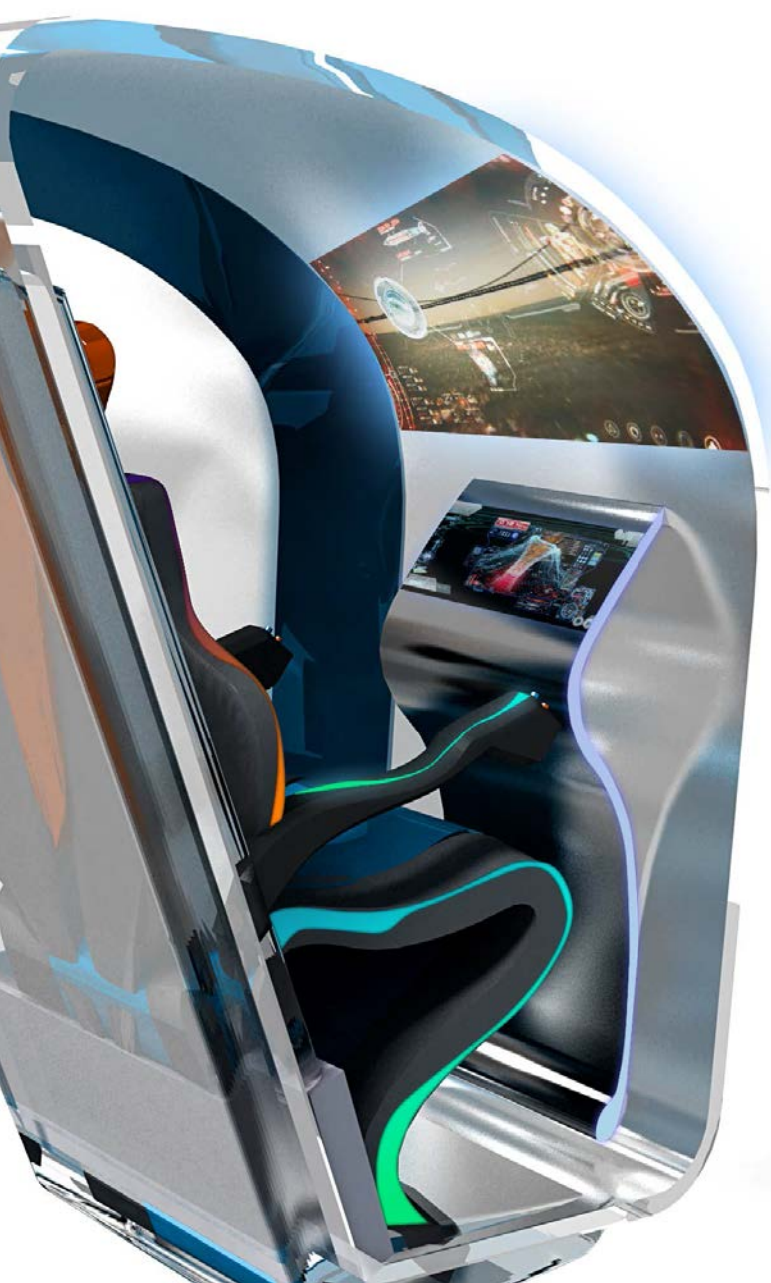



The purpose of this project is to provide more efficient, more secure building tools in the growing world construction, In essence, we subvert the people's understanding of excavators, integrate into a variety of mechanical elements, such as cranes and truck. During the research phase, we found the need of improved safety and efficiency of construction workers .Although this solution is a product design, it is based on a complete system design. We have developed a new and better excavator working system.



The most important is it adds a new possible of excavator.
It will be a brand new and excellent category of excavator.



Double jibs can increase the endurance to make sure the normal operation of the jibs and arms.

THE END

THANK YOU