

PAULS ANGUISH

Designed by Sung Won Park,
Pratt Institute, BID Industrial Design
<http://sungwprk.com>
sungwprk@outlook.com

INSTRUCTOR

Bruce Hannah,
Professor, Pratt Institute Industrial Design Dept.
<http://brucehannahdesign.com>

SPECIAL THANKS & CONTRIBUTORS

Mom & Dad
Ahhyung Chung, Graphic Designer
James O'mally, Brooklyn Design & Fabrication
Sungha Park, Photographer

COPYRIGHT

2014 Sung Won Park All Right Reserved

EDITIONS

1st Edition, May 2014

/ 7









PAUL'S ANGUISH
Stories & Symbolisms

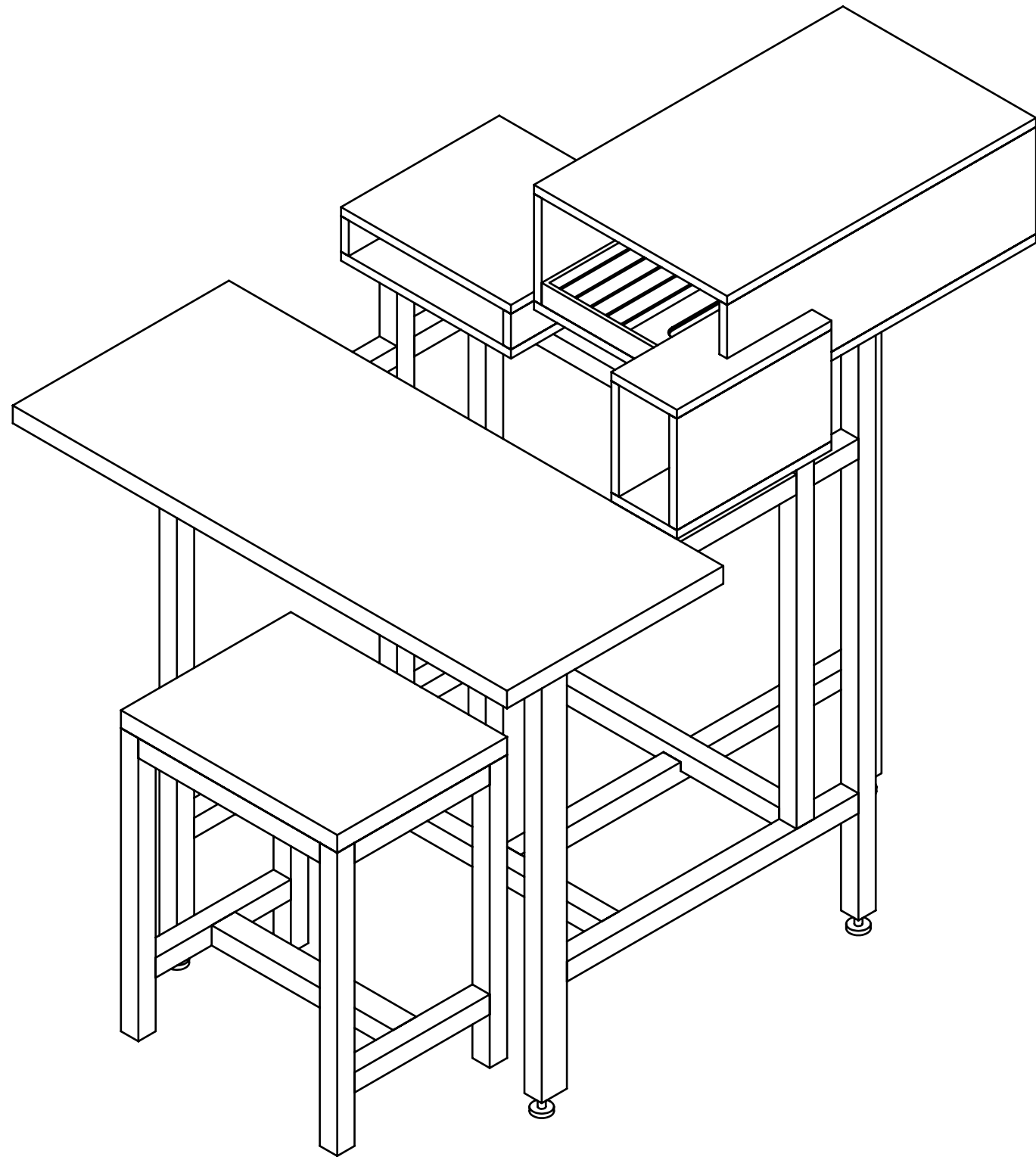

Paul's Anguish

What table would St. Paul the Apostle might use if he is living in modern age?

Fourteen out of twenty-seven books in the New Testament have traditionally been attributed to Paul. Most of his works in bibles are letters to churches - which is known as "Epistles"

Imagine St. Paul in modern age, What table he would use to write the letters to the churches?

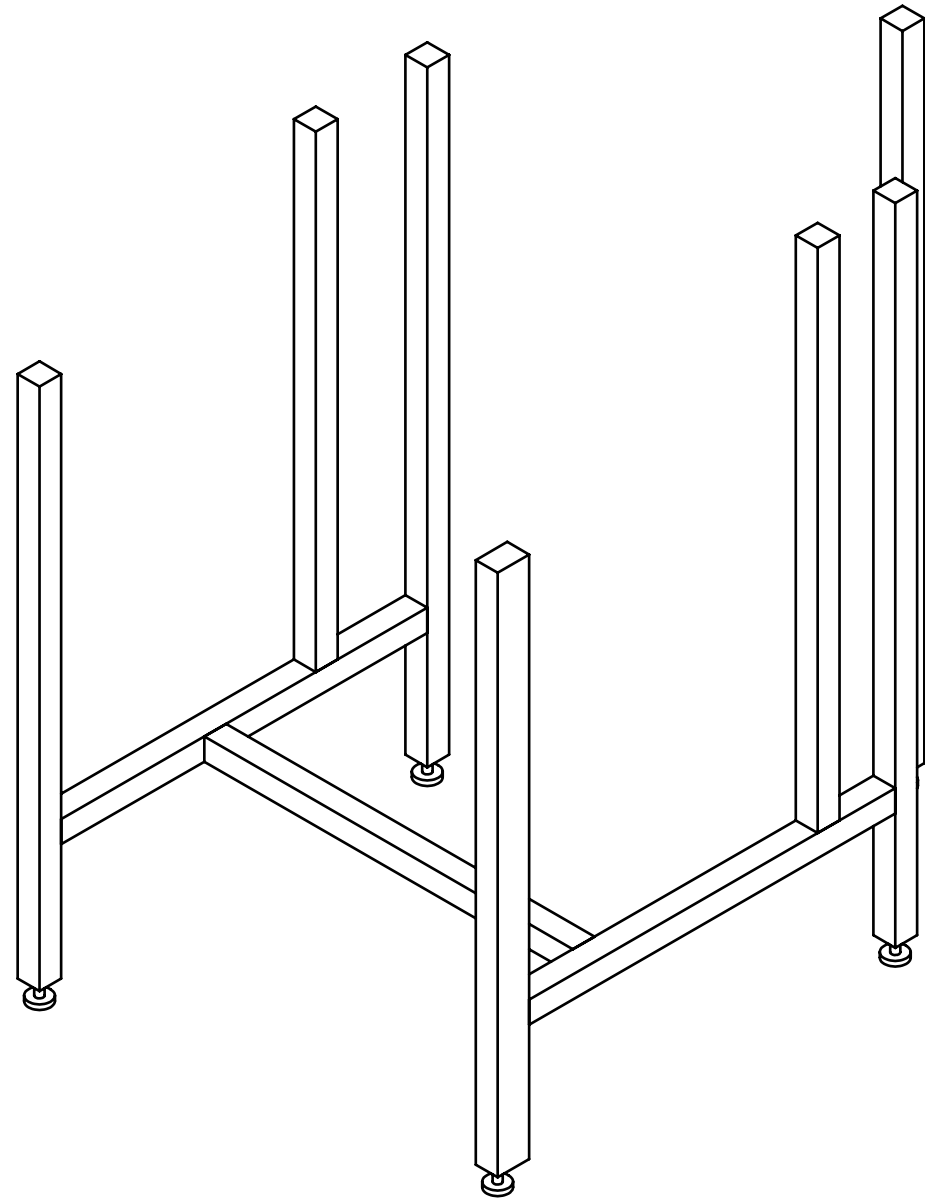

Symbolism behind Legs

Seven verticals, but only five are touching the ground.
What's the story behind?

Seven symbolizes seven early christian churches. but where is the five came from?

“They built the altar of burnt offering of acacia wood, three cubits high; it was square, five cubits long and five cubits wide.” (Exodus 38:1, NIV)

Alter was the only way to communicate with God. therefore it means God's mercy. Five is came from alter's dimension.

As a result, this means - Seven Churches are standing with God's mercy.

Cross joinery

Symbolism behind cross, Jesus Christ: Only way to reach God

Jesus answered, "I am the way and the truth and the life. No one comes to the Father except through me." (John 14:6, NIV)

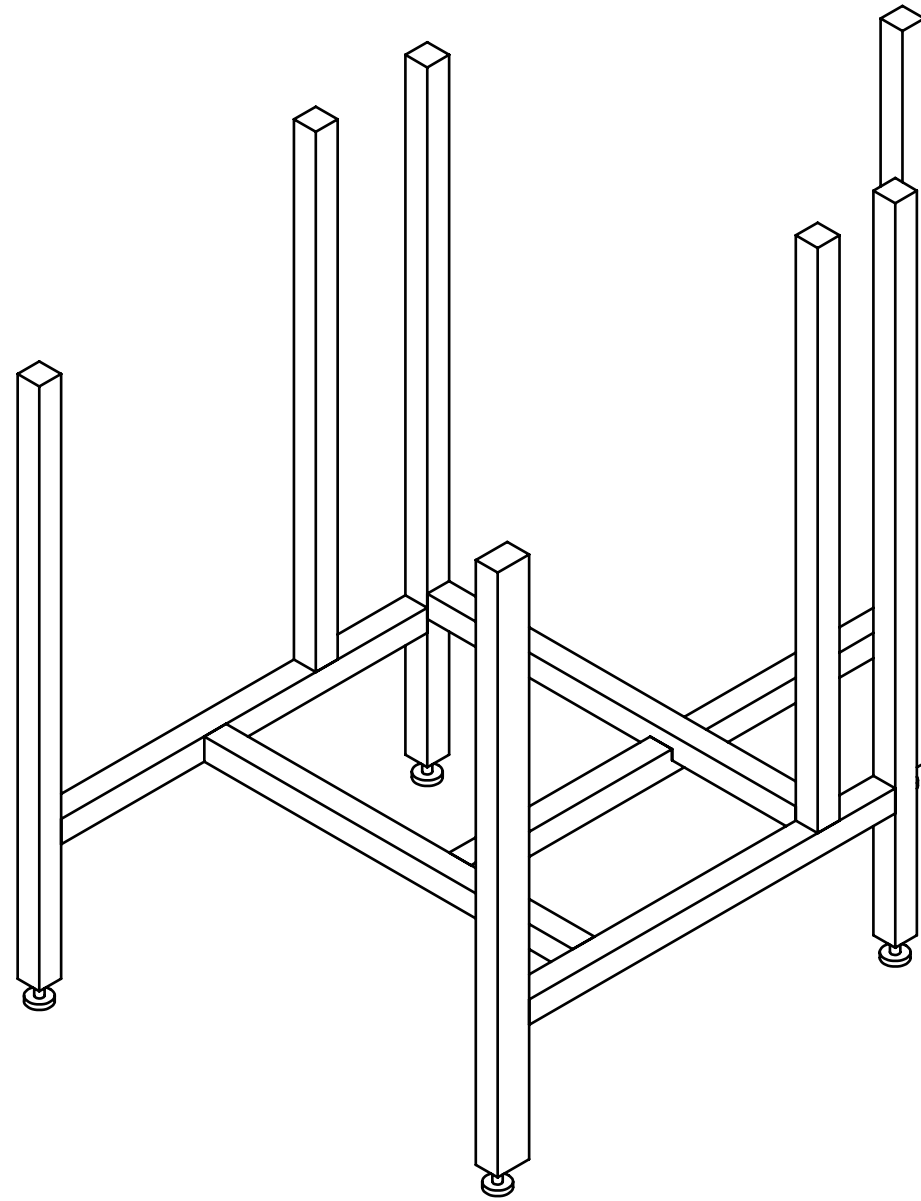

Sycamore

What is the meaning behind sycamore? Why sycamore for this table?

In the New Testament, Zacchaeus climbed into a sycamore when the crowd prevented him from seeing the Christ pass by. St. Gregory the Great called it ficus fatua and to climb into a sycamore means spiritually to partake of a measure of madness in abandoning all interest in earthy things and in all that is created. What Zacchaeus did might, therefore, symbolize the folly of being detached and certain degree of contempt for public opinion verging upon anti-conformism.

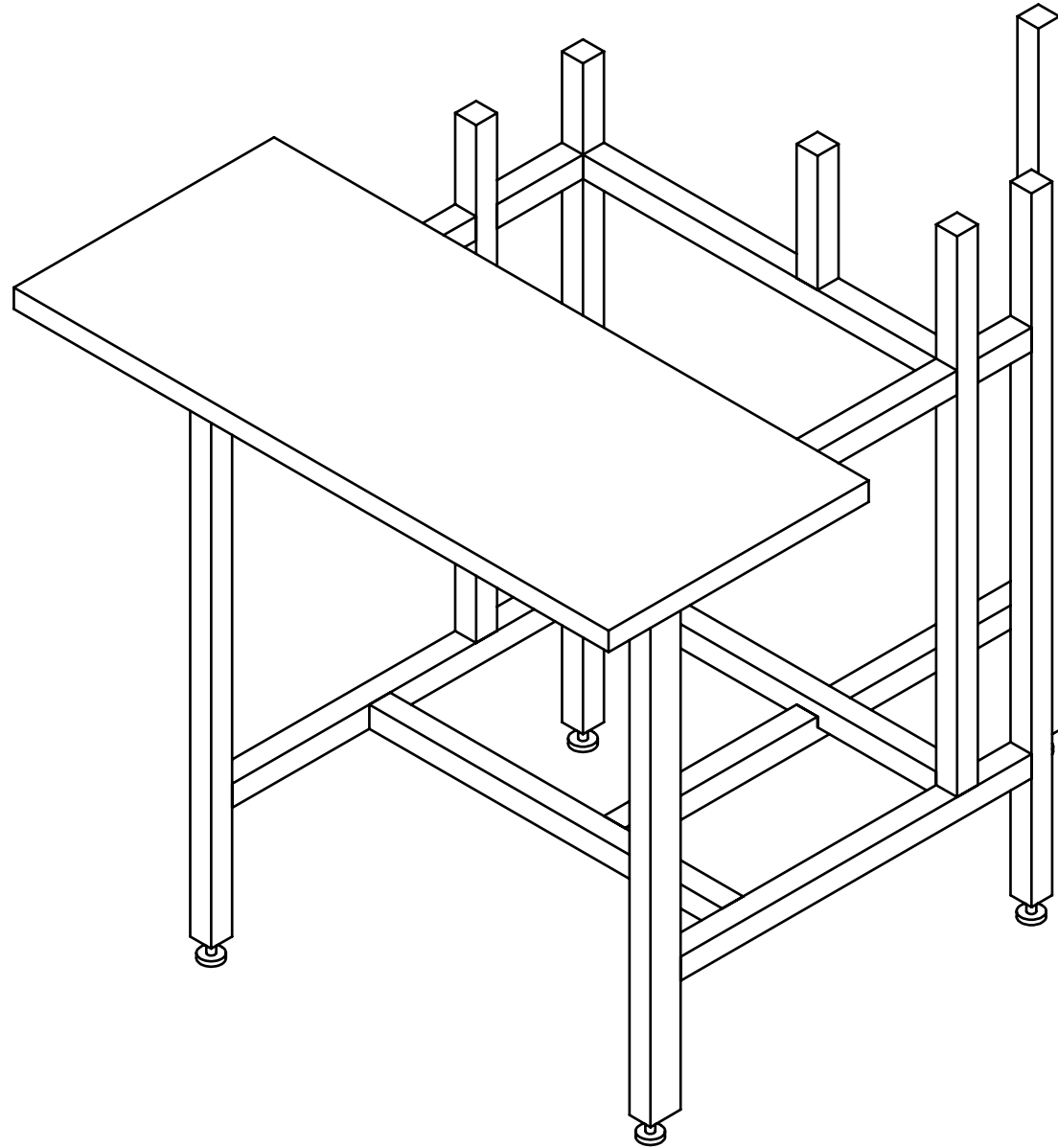

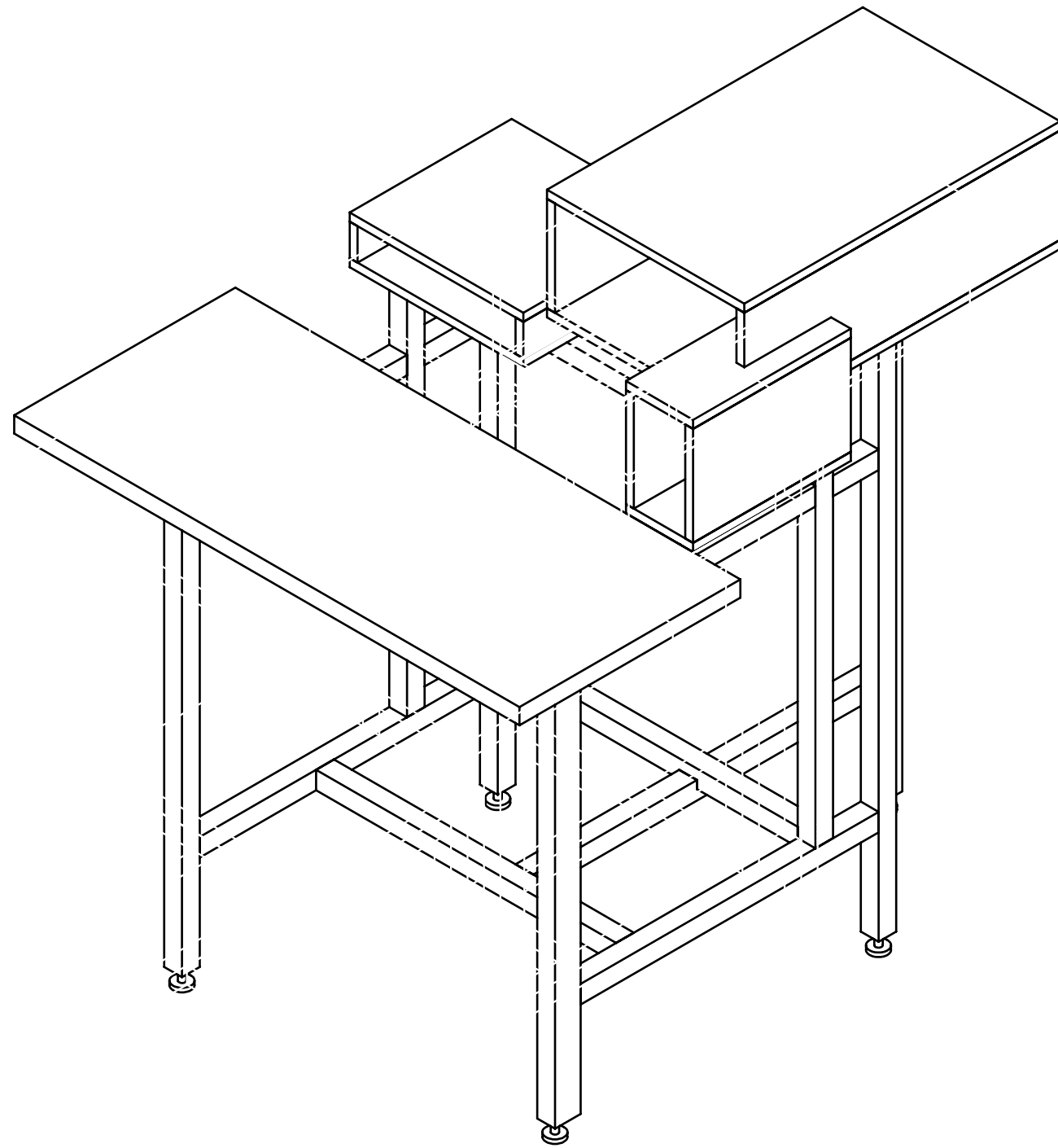

Holy Trinity

St. Paul was not writing with his own idea. He was talking with God.

Three boxes are stands for Holy Trinity: Father, Son and Holy Spirit.

Each boxes are designed to have function. left box(Son) is for paper utensil, center box(God) is for writing stationaries and box on the right (Holy Spirit) is for enveloped letter - which is about to send.

DESIGN PROCESS:
Visual Development &
Three Dimensional Studies

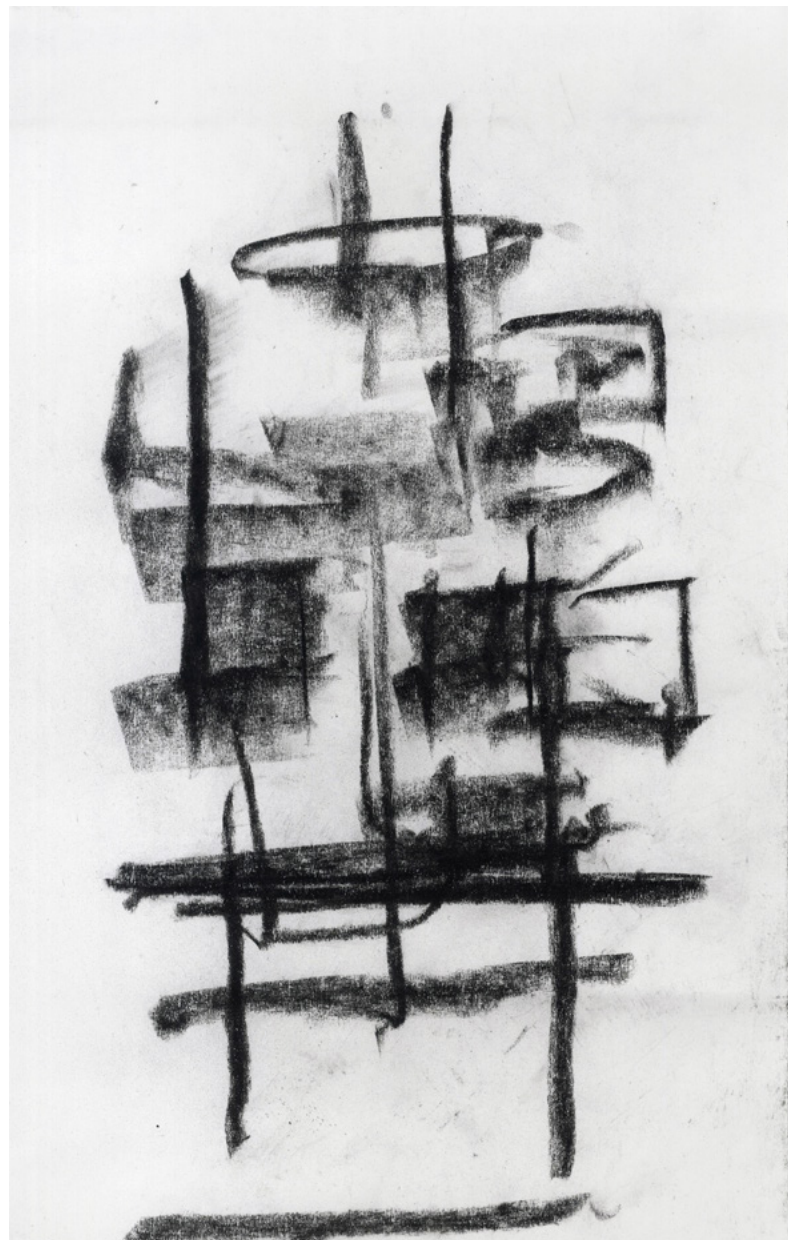

PLATE (1/40)

"Paul and Holy Trinity"

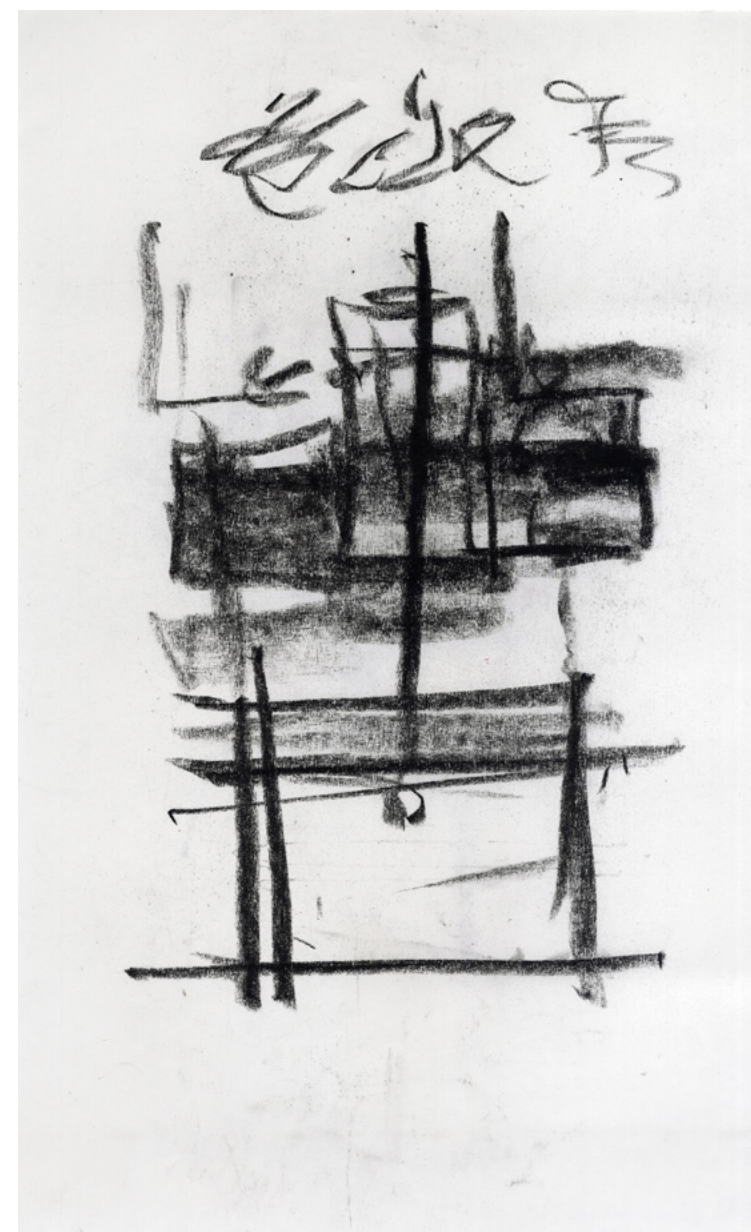

PLATE (2/40)

"Communication with Lord"

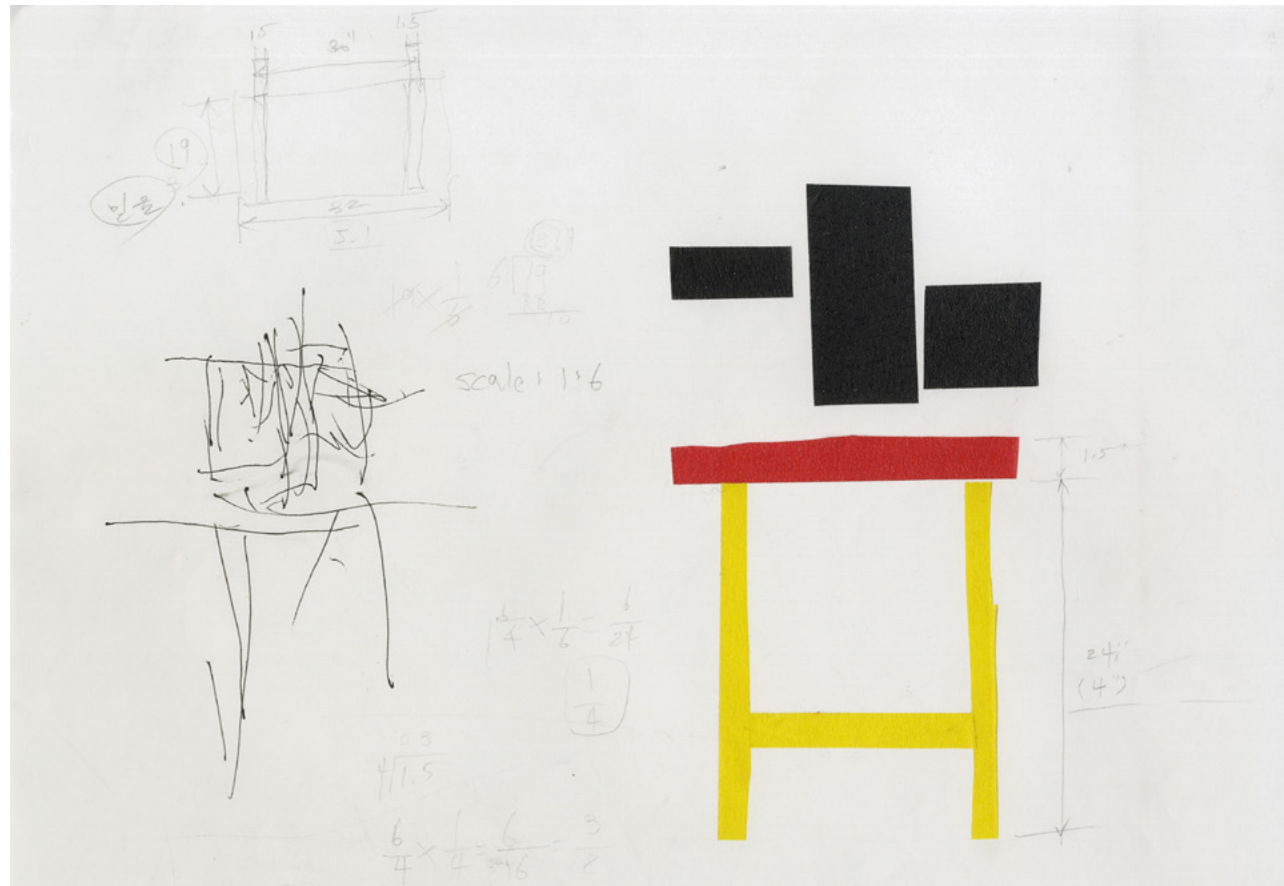

PLATE (3/40)

"Primitive I"

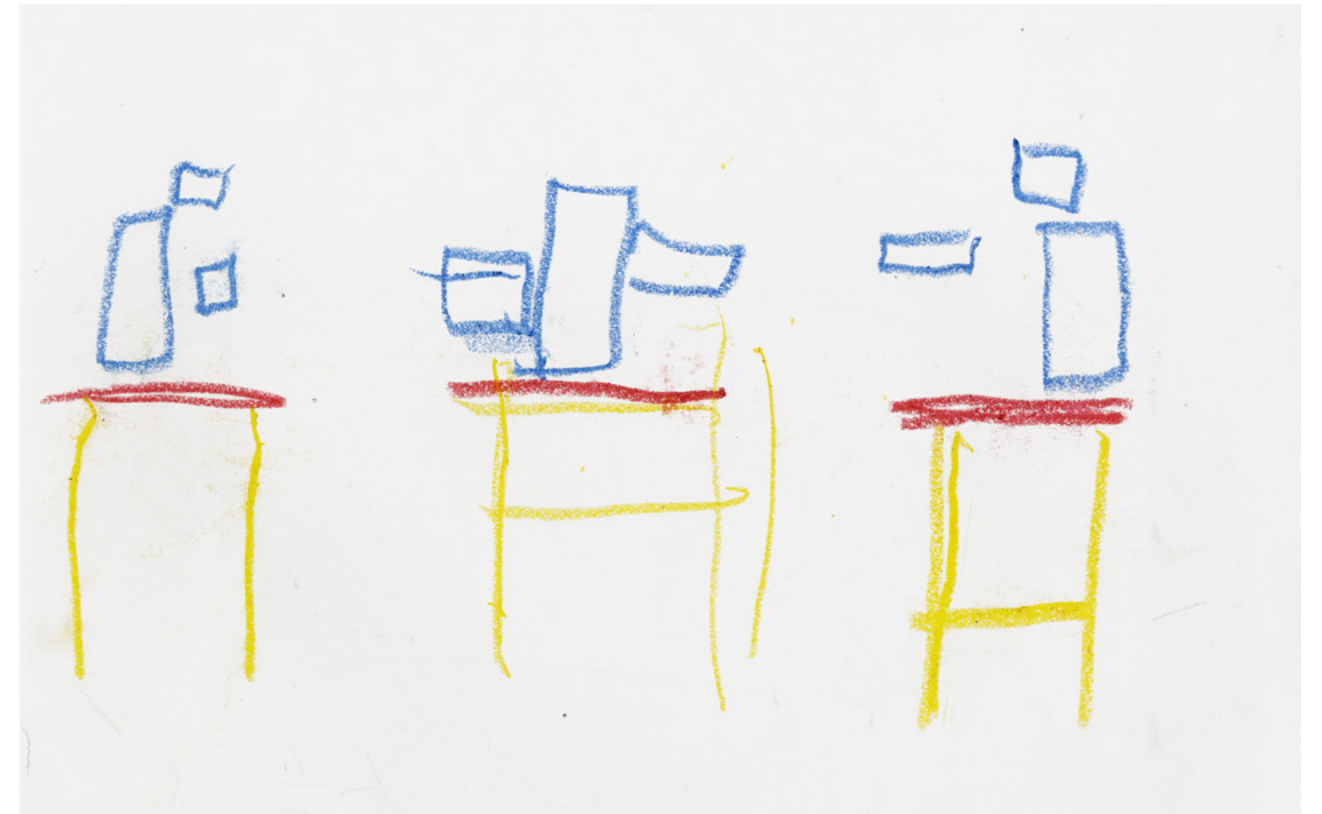

PLATE (4/40)

"Primitive II"

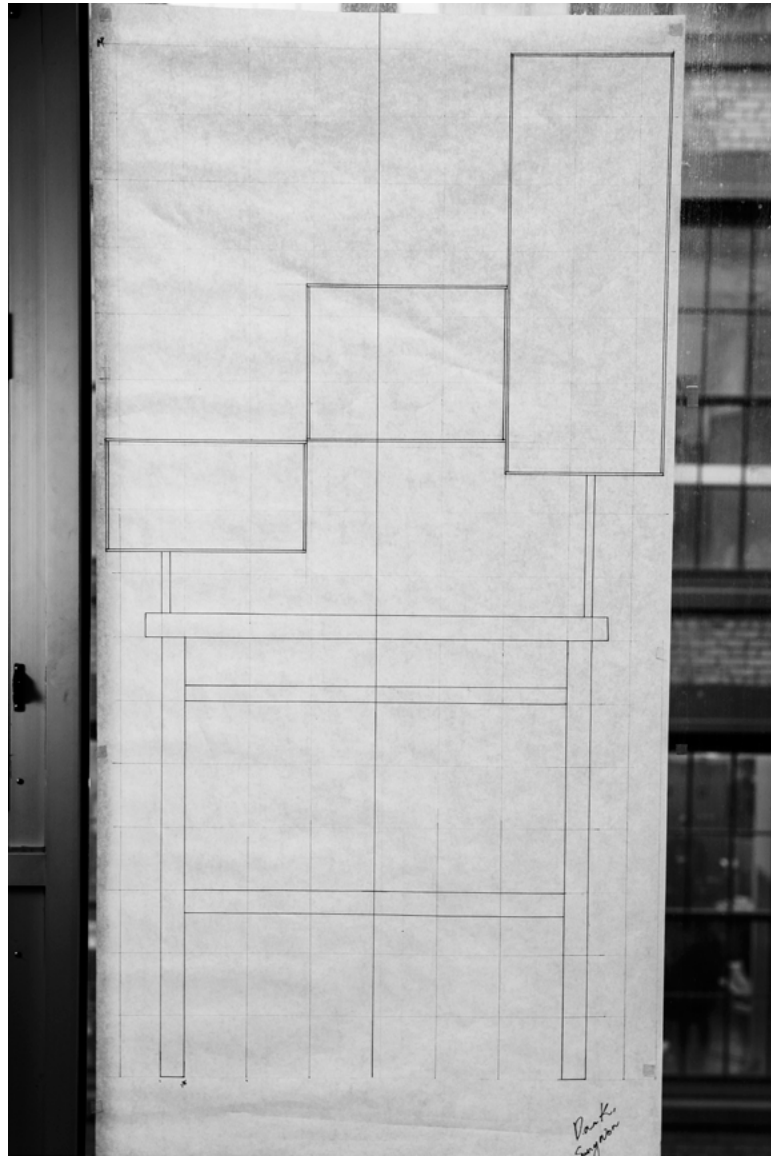

PLATE (5/40)

"Explosion"

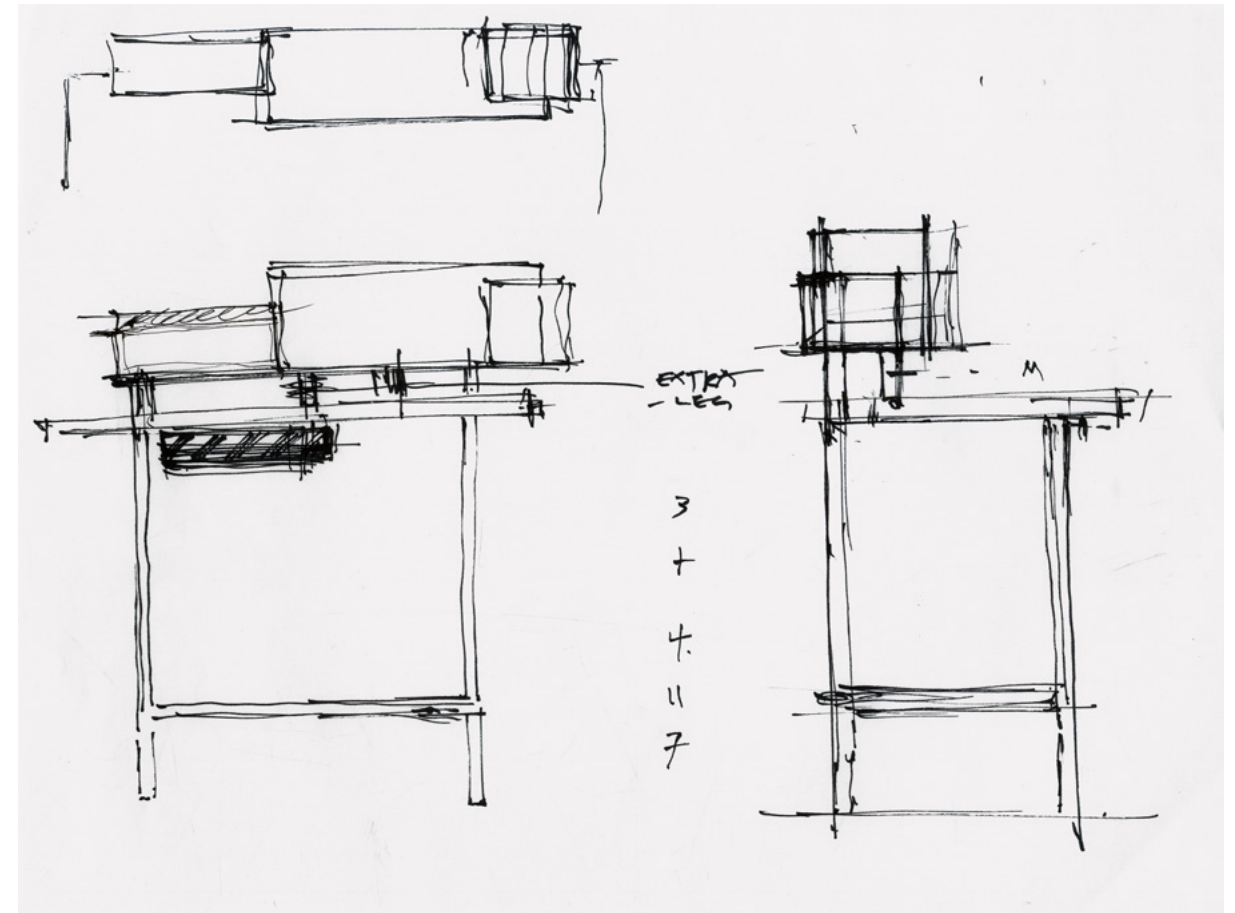

PLATE (6/40)

"Holy Numbers, Holy Table"

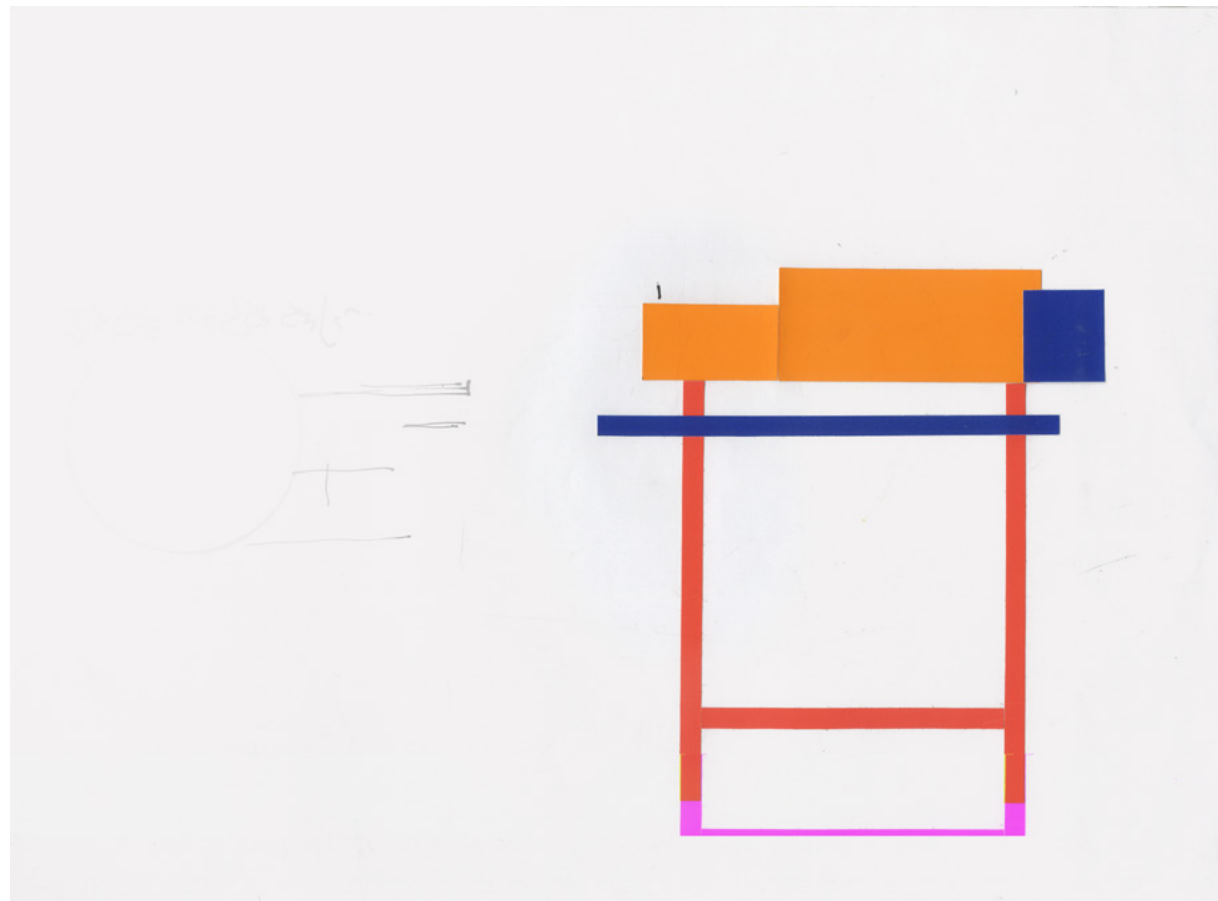

PLATE (7/40)
"Table with Color"

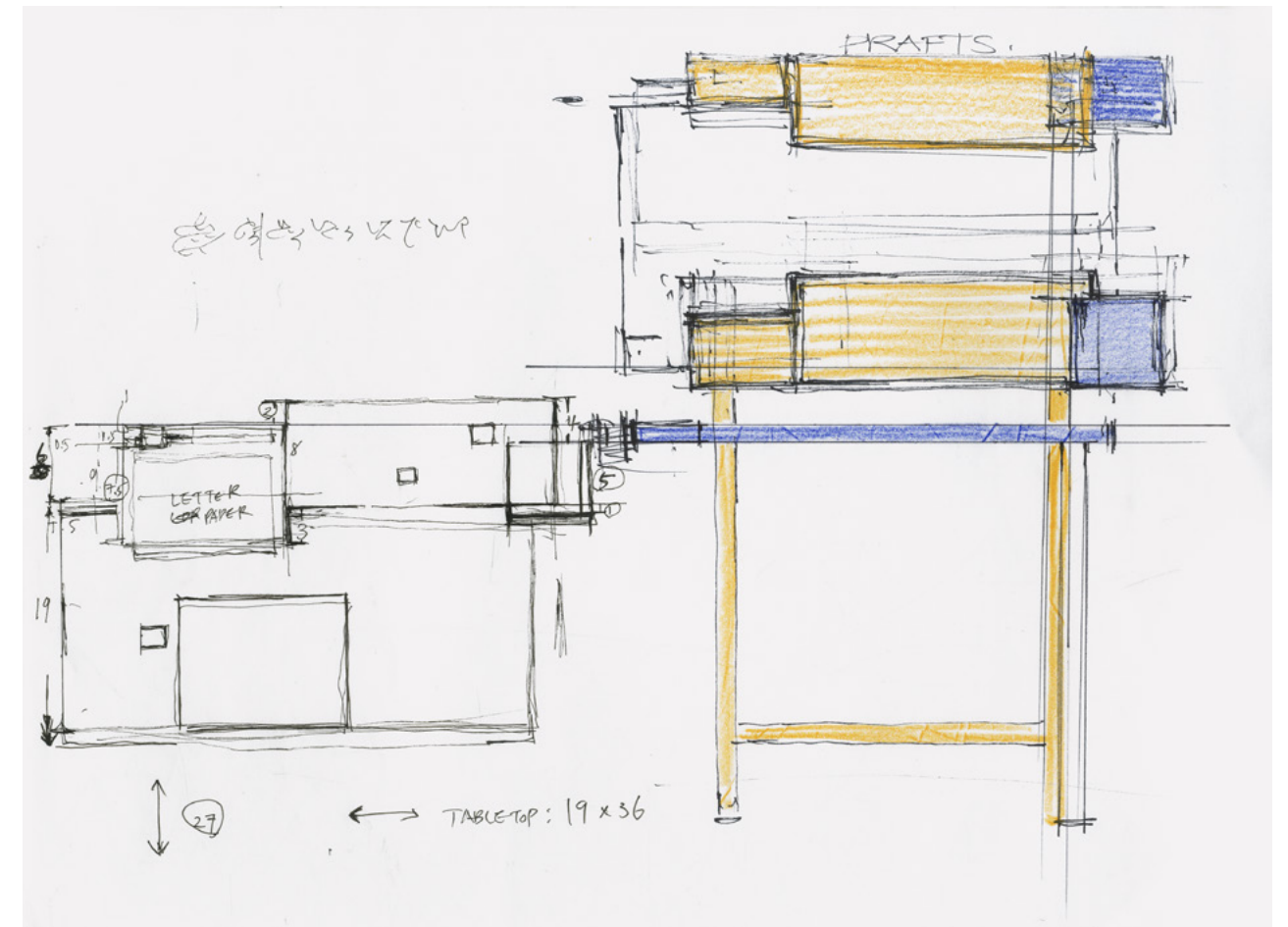

PLATE (8/40)
"Refinement I"

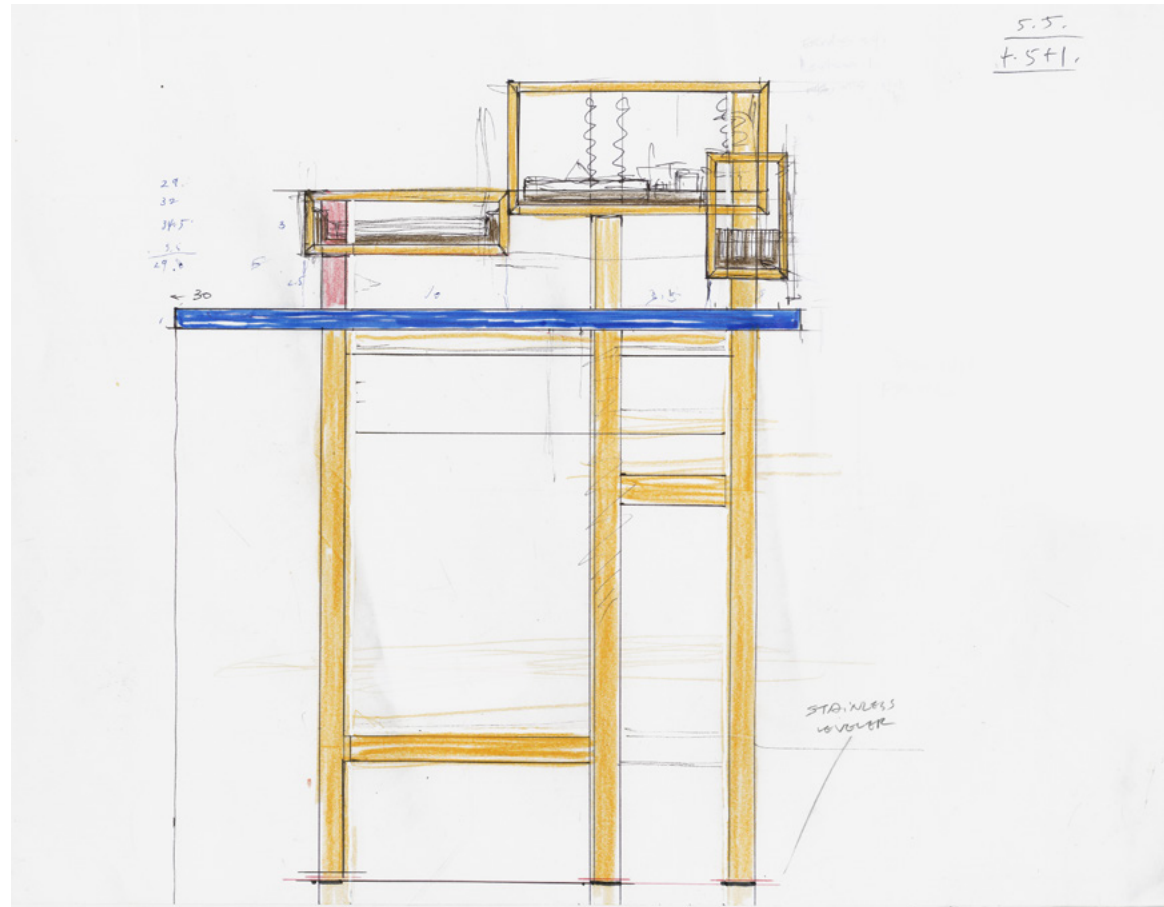

PLATE (11/40)

"Refinement III"

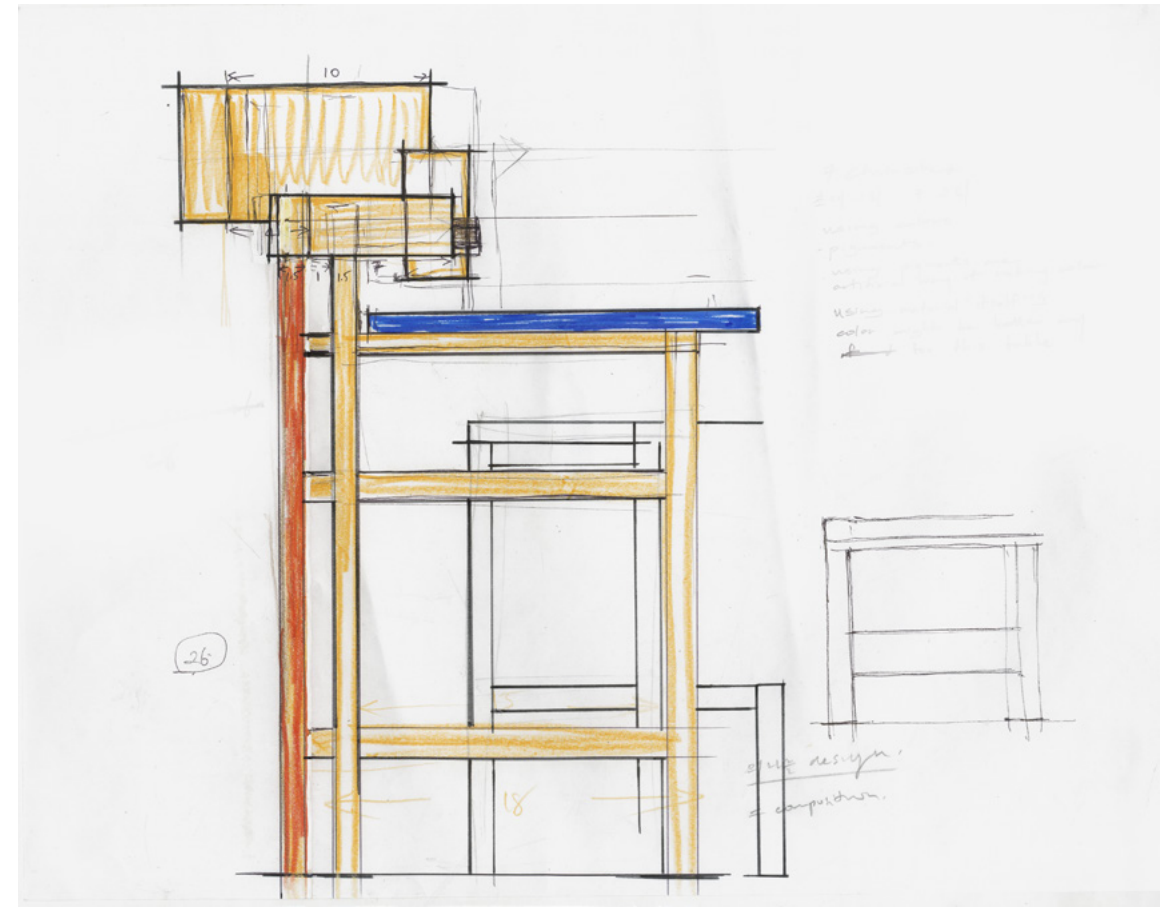

PLATE (12/40)

"Refinement IV"

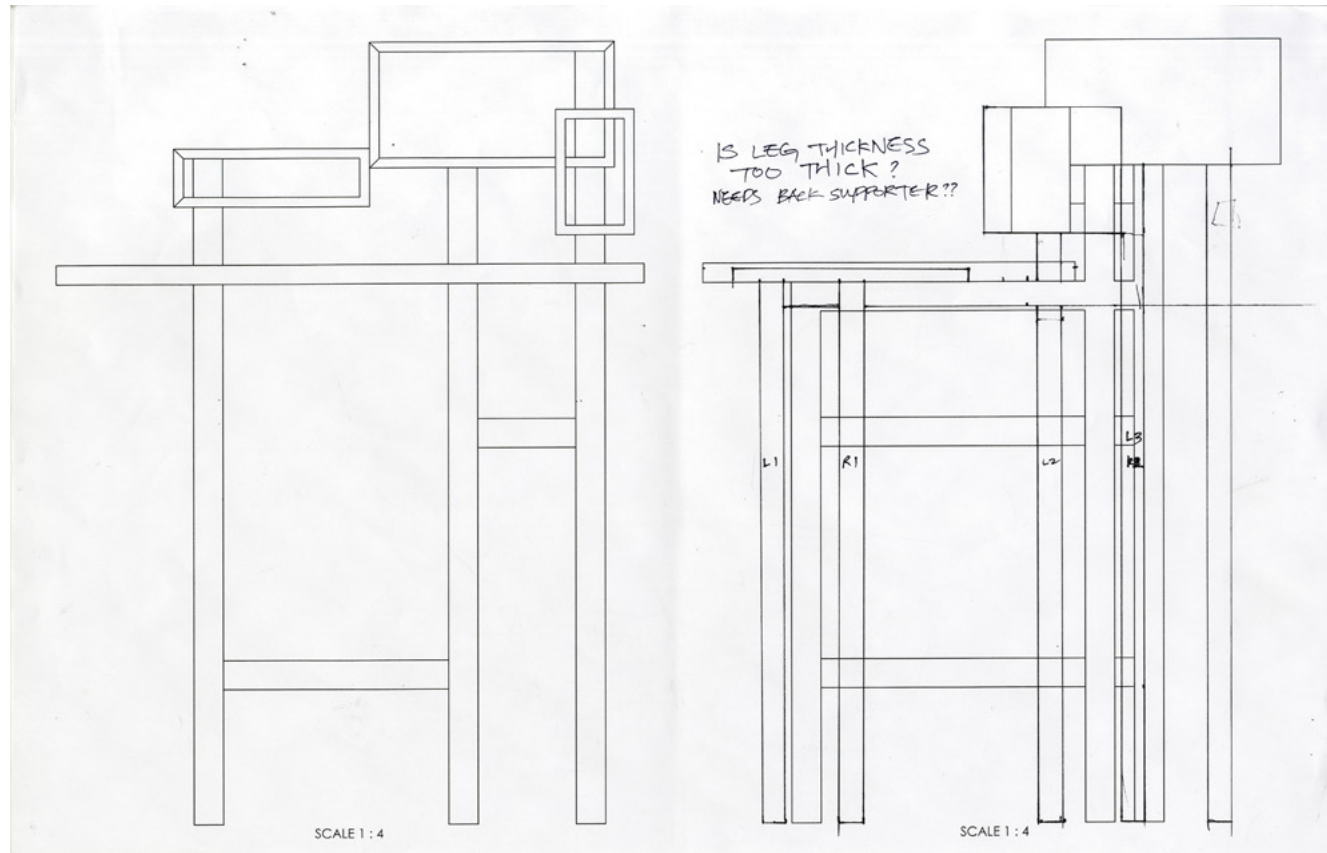

PLATE (15/40)

"Is this leg too thick?"

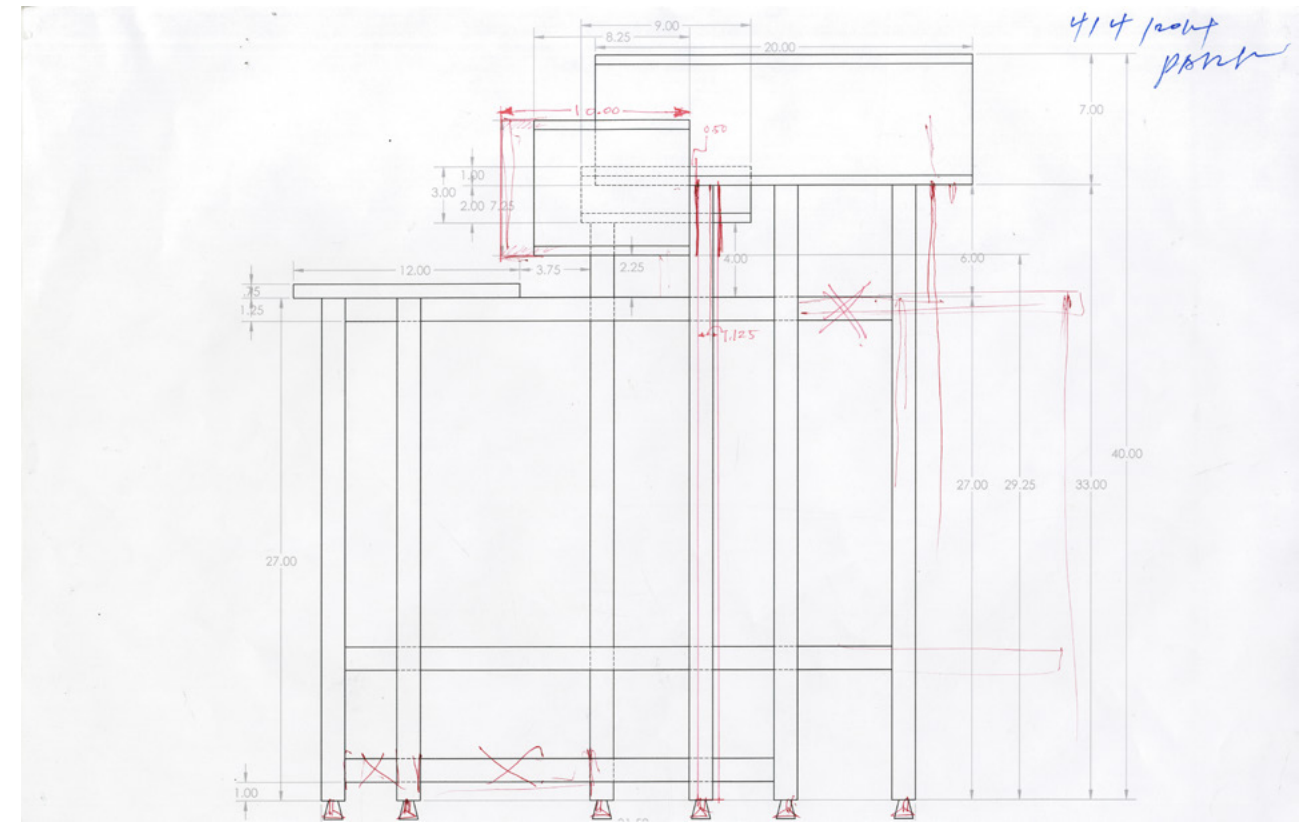

PLATE (16/40)

"Too much touching on the ground"

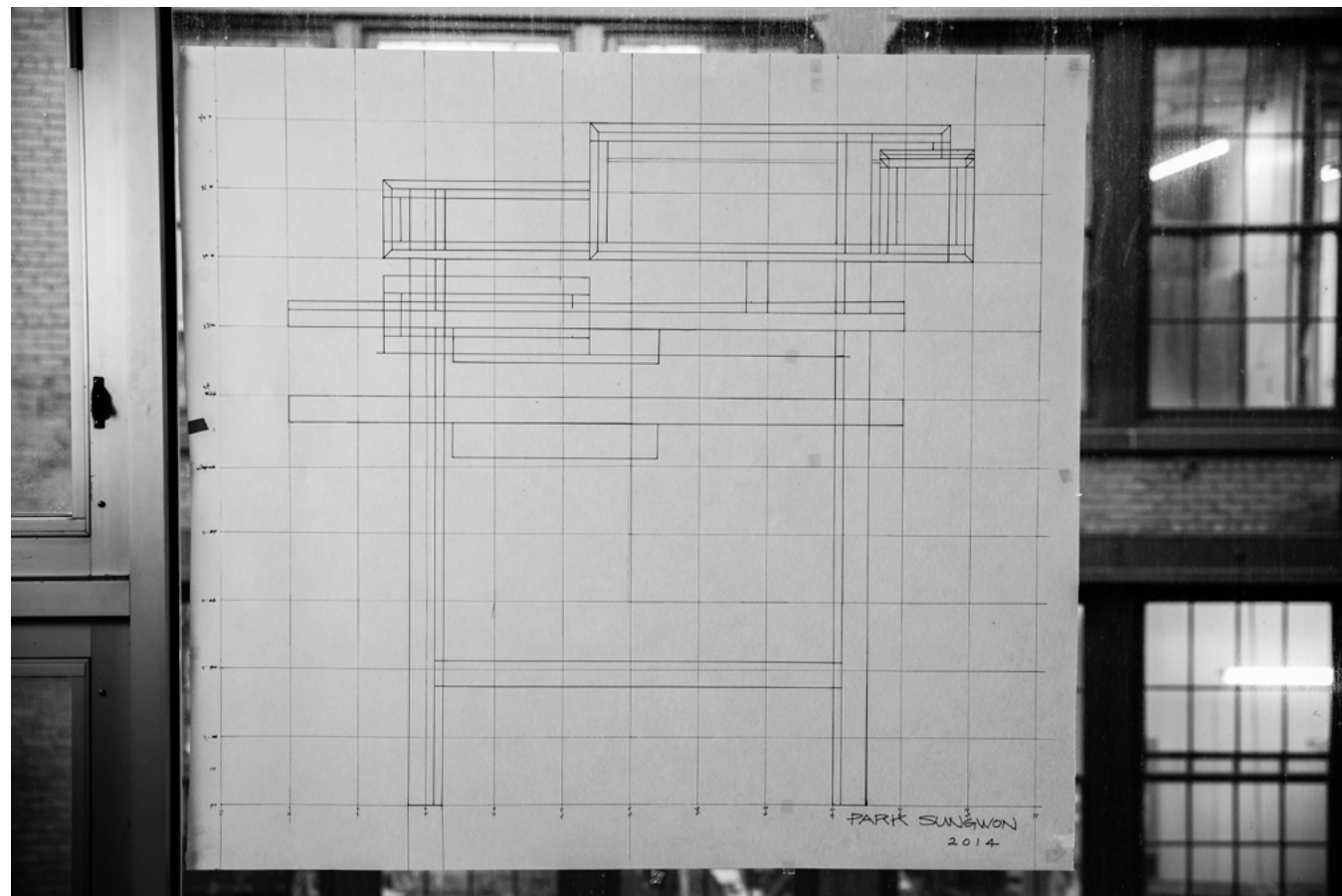

PLATE (17/40)

"Elevating Upward"

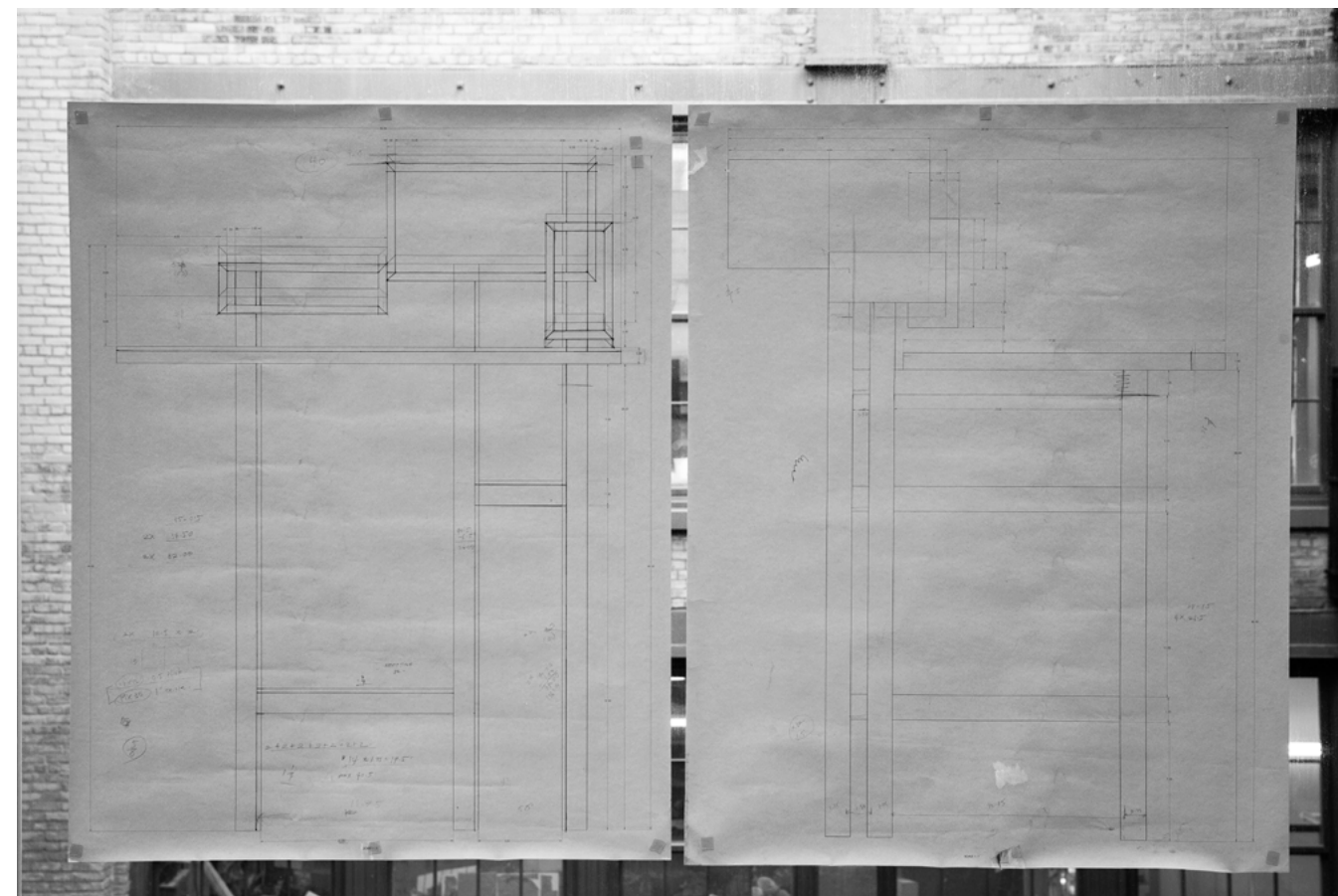

PLATE (18/40)

"Stronger"



PLATE (19/40)

“Mock it up before Fock it up I”



PLATE (20/40)

“Mock it up before Fock it up II”

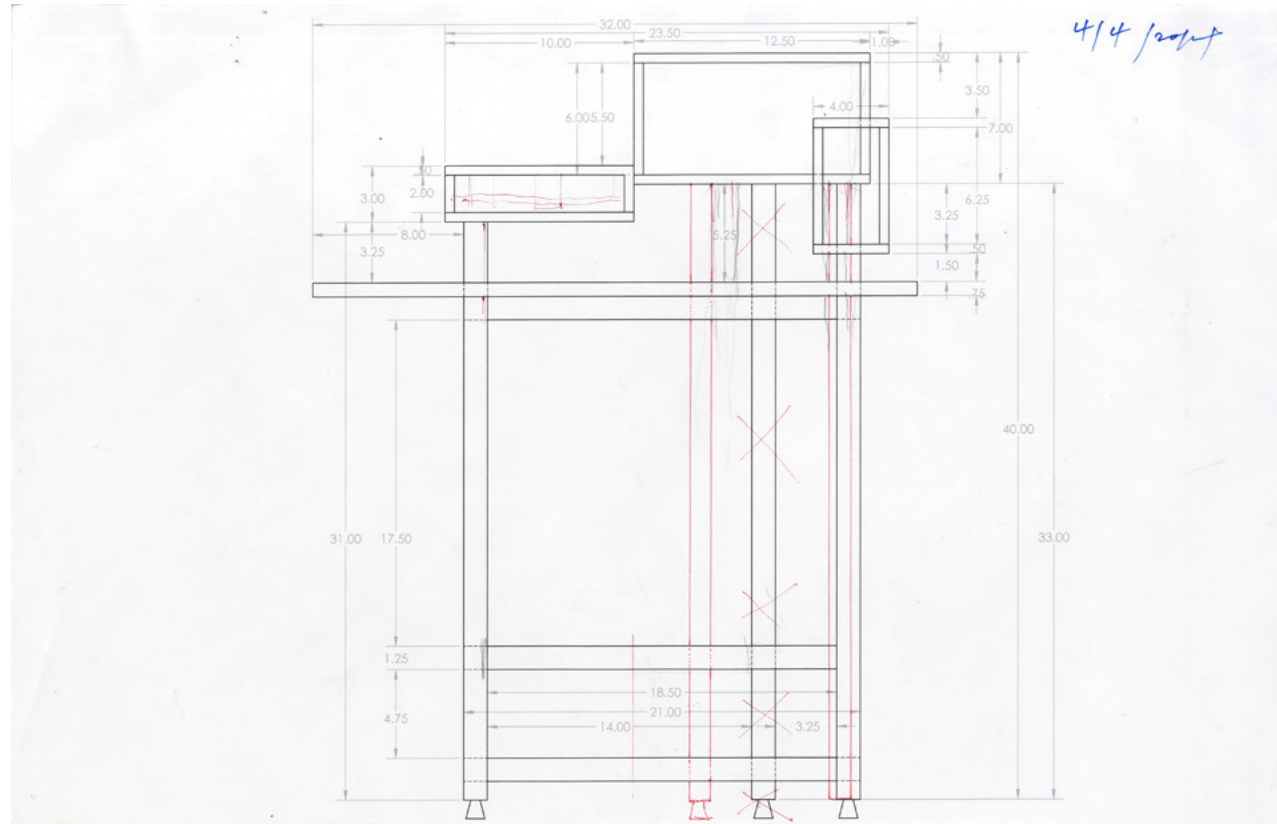

PLATE (21/40)

"Lets move this"

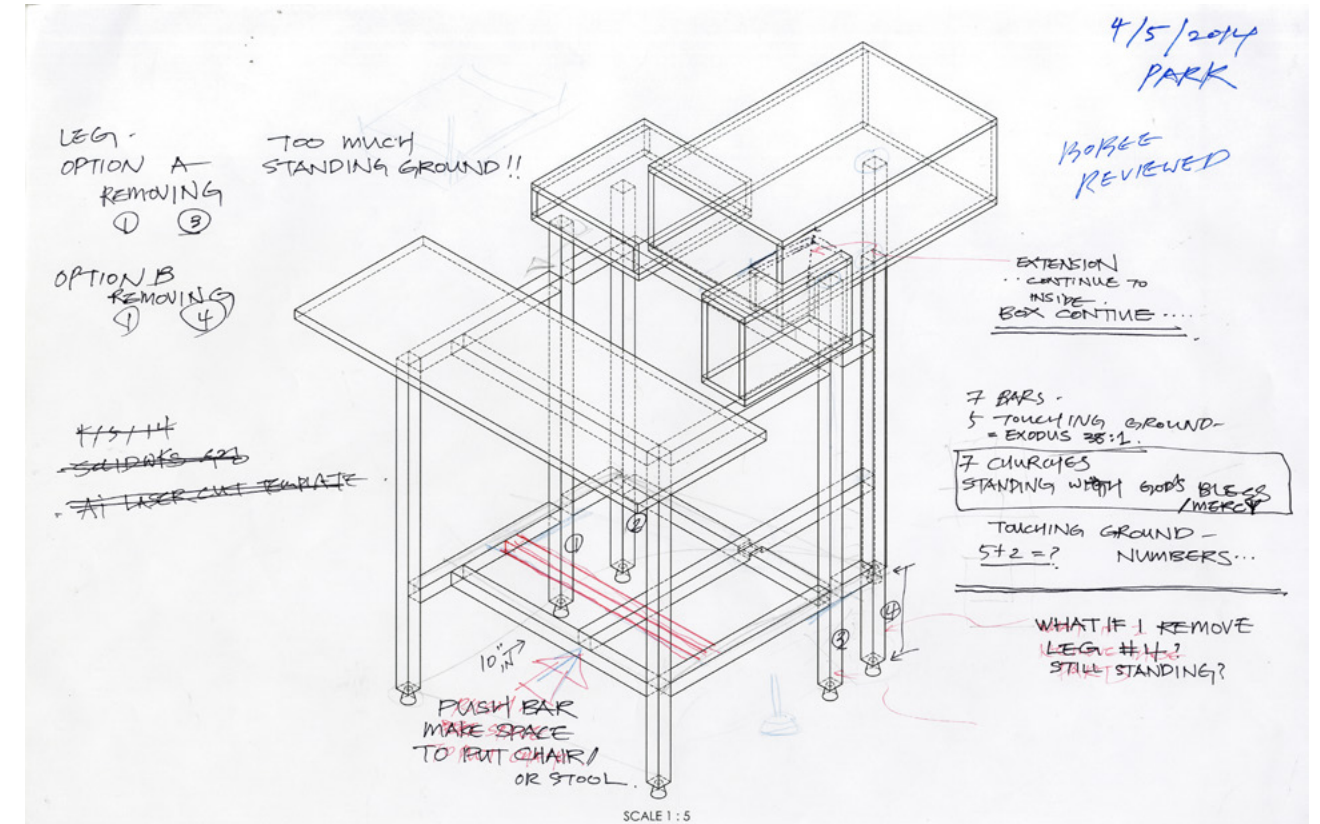

PLATE (22/40)

"Give me some space!"

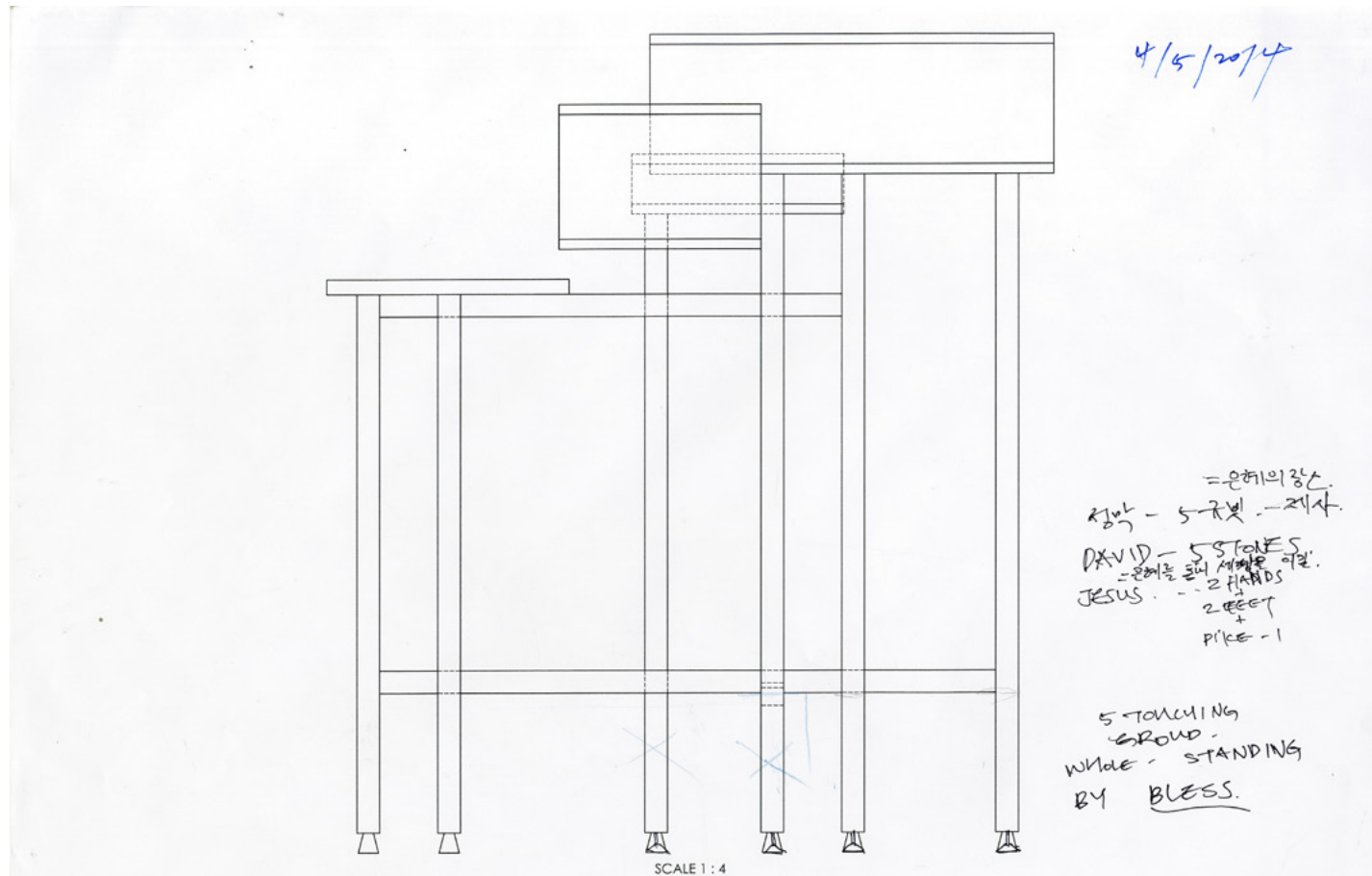

PLATE (23/40)

"Five beats the Seven"

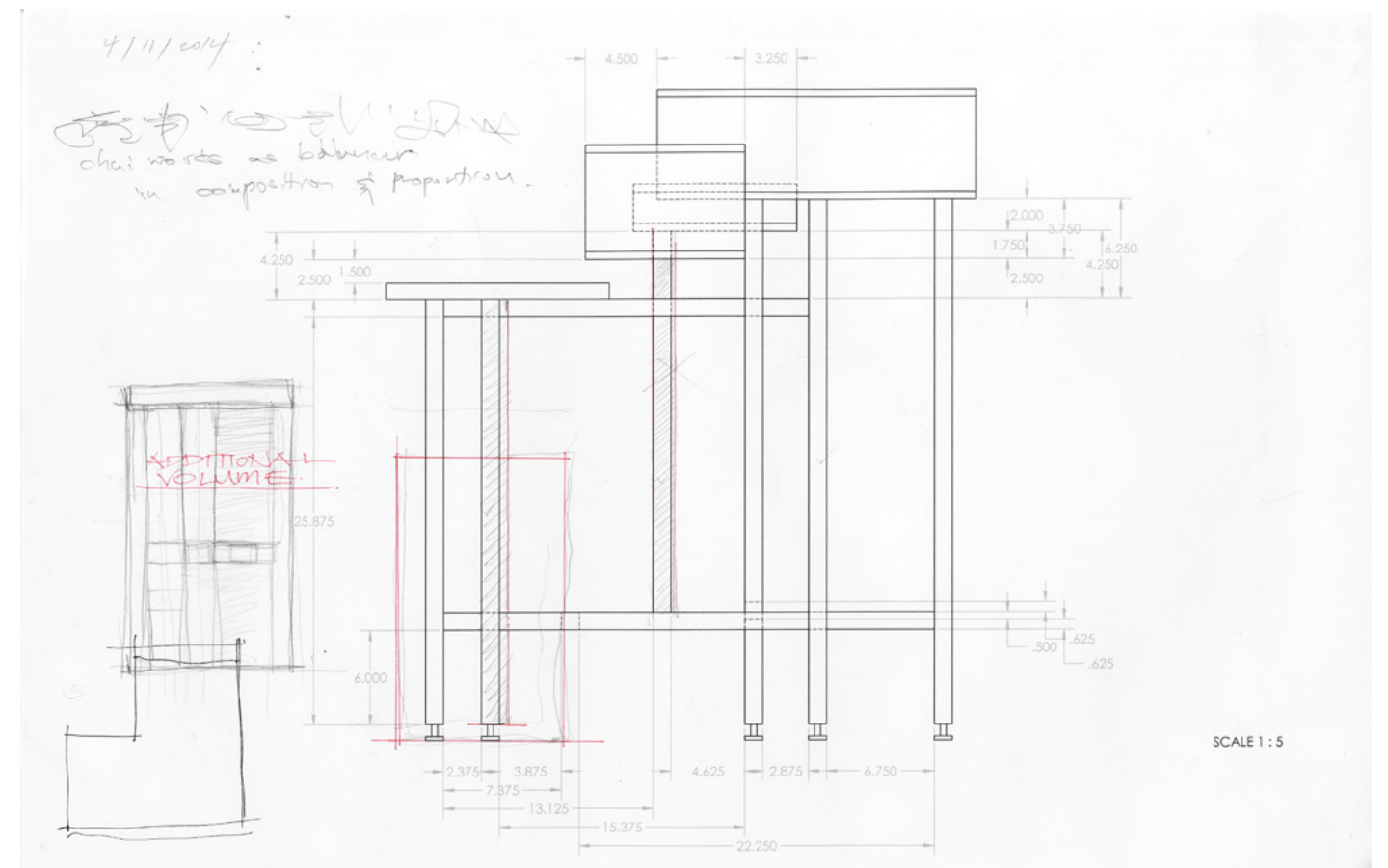

PLATE (24/40)

"Stool wants to take some part"

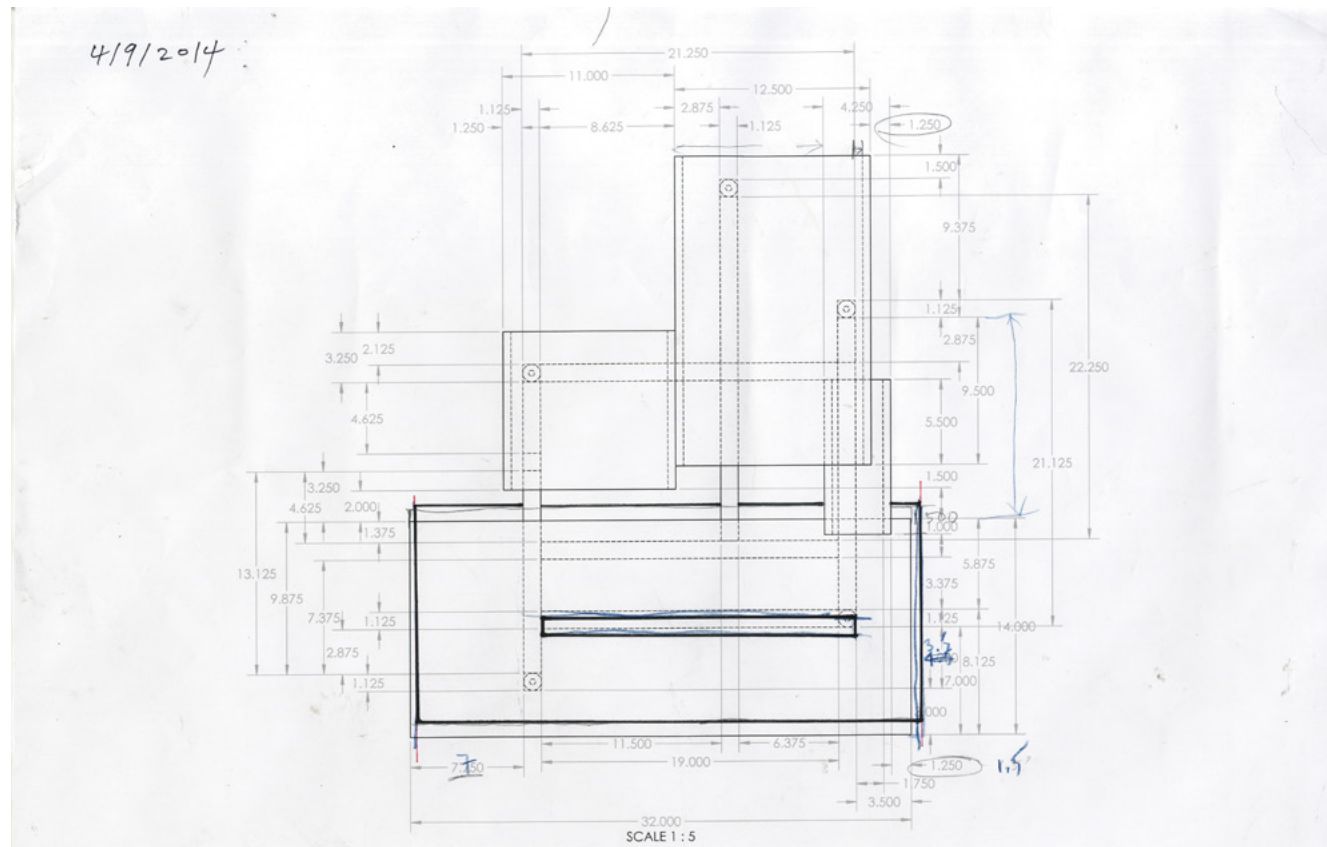

PLATE (25/40)

"Bigger and Thicker is better"



PLATE (26/40)

"Mock it up before Fock it up III"



PLATE (27/40)

“Mock it up before Fock it up IV”



PLATE (28/40)

“Mock it up before Fock it up V”



PLATE (29/40)

"Friends I"



PLATE (30/40)

"Friends II"

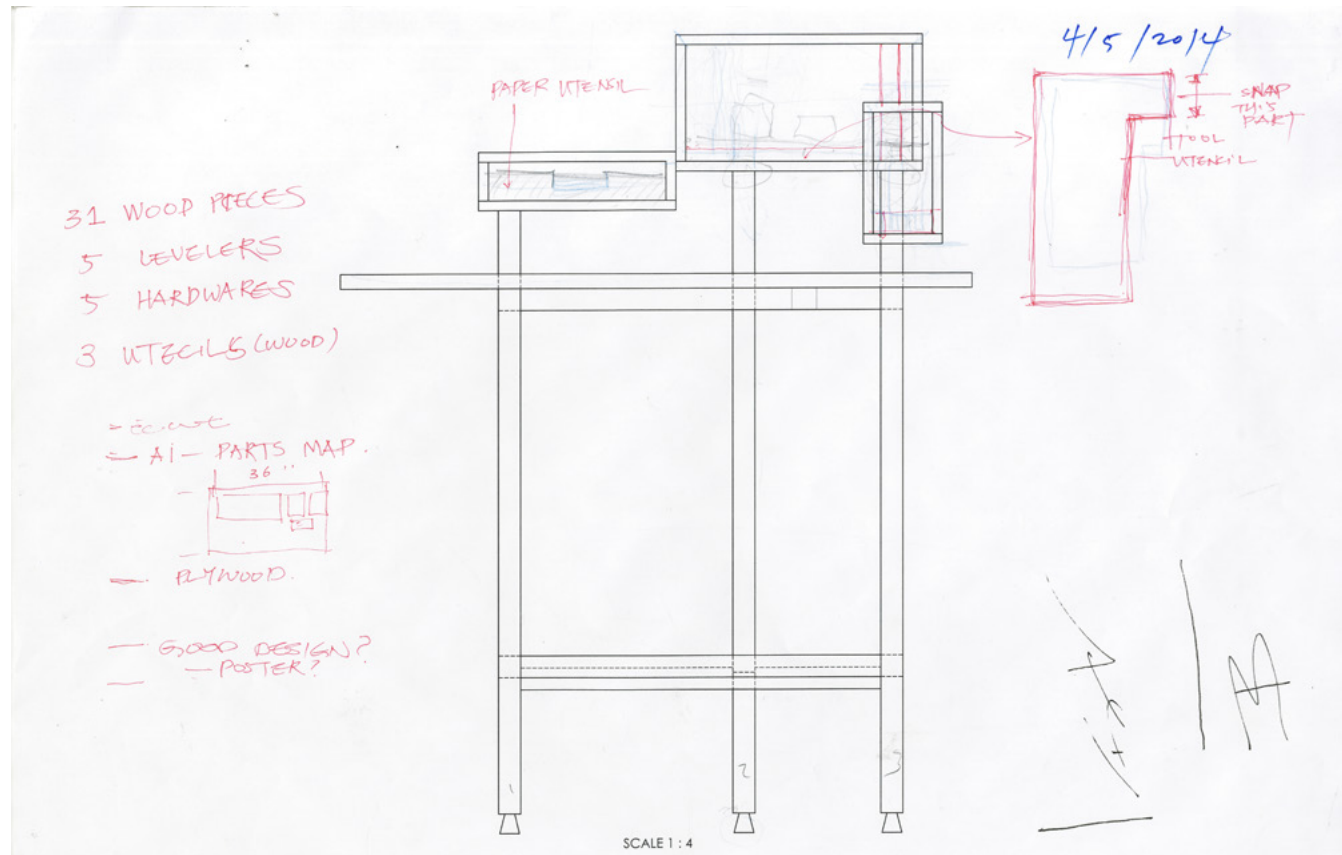

PLATE (31/40)

"Small Stuff, Big Difference"

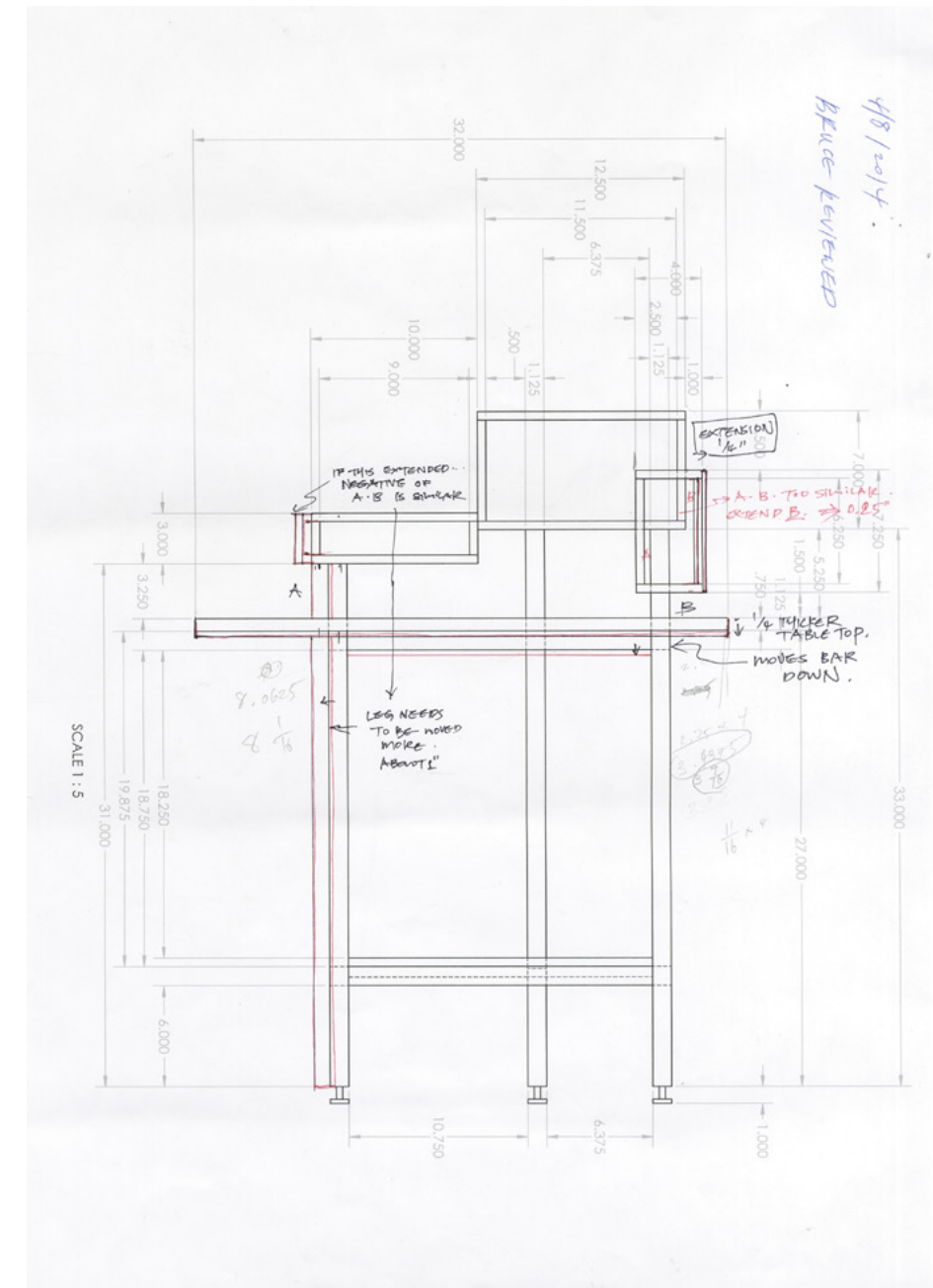

PLATE (32/40)

"Boxes wants to move"



PLATE (33/40)

“Final Modeling Process I”



PLATE (34/40)

“Final Modeling Process II”



PLATE (35/40)

“How to keep the calmness I”



PLATE (36/40)

“How to keep the calmness II”



PLATE (37/40)

“Anguish I”



PLATE (38/40)

“Anguish II”



PLATE (39/40)

“Anguish III”



PLATE (40/40)

“Anguish IV”

